

90207946

RD-145T
DAT DATA RECORDER
INSTRUCTION MANUAL

富士通株式会社
10.3A4274



TABLE OF CONTENTS

| | | |
|-----|---|----|
| 1. | OVERVIEW | 1 |
| 2. | FEATURES | 2 |
| 3. | PRECAUTIONS | 4 |
| 4. | APPEARANCE AND FUNCTIONS | 6 |
| | 4-1) Appearance | 6 |
| | 4-2) Reference Numbers | 7 |
| | 4-3) Names and Functions | 9 |
| 5. | OPERATION METHOD | 17 |
| | 5-1) Basic Operation | 17 |
| | 5-2) Input Connections and Tape Speed, CH MPX, and Setting of Input Range | 20 |
| | 5-3) Output Connection and Level Adjustment | 20 |
| | 5-4) Memo (Announcement) Recording or Reproduction | 21 |
| | 5-5) Data Sound Monitoring | 21 |
| | 5-6) ID Recording and Reproduction | 21 |
| | 5-7) Recording with the Counter | 23 |
| | 5-8) CLOCK Recording | 24 |
| | 5-9) Reproduction Tape Speed Setting | 24 |
| | 5-10) Search Operation | 24 |
| | 5-11) End Search (E SEARCH) | 25 |
| | 5-12) Erasure | 25 |
| | 5-13) Digital Channel Mode (CH1) | 26 |
| 6. | MAINTENANCE | 29 |
| 7. | CONFIGURATION | 32 |
| 8. | STANDARD ACCESSORIES | 32 |
| 9. | OPTIONS | 33 |
| 10. | SPECIFICATIONS | 34 |
| | 10-1) Major Specifications | 34 |
| | 10-2) I/O Specifications | 34 |
| | 10-3) Digital Channel (Analog channel CH1 is switched) | 35 |
| | 10-4) Operating Conditions | 35 |
| | 10-5) Functional Specifications | 35 |
| | 10-6) Others | 36 |
| | 10-7) External View | 37 |

90197536

No. 3A3642



1. OVERVIEW

The development of personal computers in recent years has promoted the automation of measurement processing. This trend has required improvements to the functions and accuracy of various types of data recorders.

The RD-145T is a high-density multiplex PCM data recorder utilizing helical scanning recording techniques on standard DAT tape. The RD-145T data recorder provides improved features and benefits of two tape speeds, up to 16 selectable number of data channels, expanded recording frequency band, improved phase characteristics, high signal-to-noise-ratio, selectable recording time, and reduced physical size as compared to existing data recorders. The RD-145T can also automatically record memo sound, time codes, counter values, and data numbers (ID numbers) with the dedicated channels (which are independent of the data channels) and has a high-speed search function utilizing the data number (ID number). Measurement accuracy is increased as a direct result of these features.

Despite its compact design, the RD-145T is designed to operate from multiple power sources, including 90 to 264 Vac input, 11 to 30 Vdc input, and an optional rechargeable battery. This capability to operate from multiple power sources provides the RD-145T with maximum flexibility for laboratory use and outdoor field use.

An optional GP-IB interface unit, GP-302, connected to the data recorder enables a host computer to control data recorder functions, thereby facilitating automatic measurement. By utilizing x1 (standard speed) reproduction except CH1-16 recording, and the optional MB-300 expanded memory board with the GP-302, digital data can be stored into buffer memory and retrieved for processing.

The easy-to-use DAT recording media are cassettes conforming to the DAT conference standards. The recording method used by the RD-145T also conforms to the DAT standards.

2. FEATURES

1) Two tape speeds

Recording and reproduction will be made at a speed (x1) matching to the DAT specification or a speed two times (x2) the DAT specification. In 4, 8 or 16 channel recording with the x2 speed mode selected, recording frequency is extended to 2 times the bandwidth obtained at x1 speed. A tape recorded at the x2 speed can be reproduced at the x1 speed or a tape recorded at the x1 speed can be reproduced at the x2 speed.

2) Multi-channels and wide band

The RD-145T allows record channel selection of 2, 4, 8 and 16 channel selection at the x1 tape speed. The record bandwidth is 20kHz for 2 channels, 10kHz for 4 channels, and 5kHz for 8 channels and 2.5 kHz for 16 channels. At the x2 tape speed, RD-145T allows recording channel number selection of 4, 8, and 16 channels. The record bandwidth is 20kHz for 4 channels, 10kHz for 8 channels and 5 kHz for 16 channels.

3) Digital input

CH1 accepts analog inputs or 14 bit parallel digital inputs switched. The digital signals enter or output through the multiconnector on the rear panel. This allows recording of 14 channel contact signals, externally converted A/D signals, etc., thus extending application fields of the data recording.

4) High-quality data (accuracy)

A desired input range can be selected among four ranges. An ADC using the delta sigma method is used for each channel. The 64-fold over-sampling digital filter provides the satisfactory anti-aliasing characteristics. An octuple over-sampling digital filter is used for output. Using filters designed to suit the purpose provides the following high-quality data. The signal-to-noise ratio is 75 dB. The frequency characteristic flatness is +0.5 dB, -1 dB. The phase difference between channels is 2° or less (at same input range).

5) Small and compact

The data recorder is approximately 306 mm wide x 128 mm high x 280 mm deep ($12\frac{1}{16} \times 5\frac{1}{16} \times 12\frac{1}{16}$ in.), and weighs approximately 7.5 kilograms (16.5 lbs). The data recorder is therefore very portable.

6) Long recording time

When a 120 tape (approximately 60 m) is used, data can be recorded continuously for two hours by x1 speed.

7) Three power supplies

The RD-145T operates on either ac input of 90 to 264 volts, dc input of 11 to 30 volts, which are provided normally, and an optional rechargeable battery unit. The battery unit can be incorporated by mounting it on the data recorder. The RD-145T can be used both indoors and outdoors.

8) Easy operation

The RD-145T is designed so that an operation button corresponds to one function as much as possible. These operation buttons facilitate operations for recording on a site.

9) Memo sound channel

In addition to the data channels, a channel used only for voice recording and reproduction is provided. Since the microphone built into the data recorder is provided normally for recording, environmental sounds can always be recorded during measurement.

10) Time code recording channel

In addition to the data channels, a channel used only for recording and reproduction of time codes is built in. The year, month, day, hours, minutes, and seconds of the built-in clock with perpetual calendar are automatically recorded. Since the time code is always automatically recorded, it can be used to confirm the recording time of measurement data on the display.

11) Data number (ID number) recording channel

In addition to the data channels, a channel used only for recording and reproduction of ID numbers is built in. The ID number of the recorded data is automatically recorded. The ID number is incremented by one each time recording starts or the EVENT button is pressed.

12) High-speed search

The recorded ID number can be searched for at high speed during reproduction. The search is performed both in the forward and reverse directions. When the target ID number is found, the target data is reproduced from the beginning.

13) Bar meter monitor

All channels can be monitored at one time with the 6-segment display bar meters. In this case, the memo sound channel can also be monitored. The signal level can be monitored both during recording and reproduction.

14) Speaker monitor

The memo sound and the data of any data channel can be heard from the built-in speaker.

15) RD series and tape compatibility

Tape compatibility is established among RD-120T(TE), RD-130T(TE), RD-125T/RD-135T, RD-180T, and RD-200T as long as both the models use a common channel mode (MPX mode). (Except a certain type of code information). However, some functions obtained with a tape recorded by RD-180T and RD-200T are not obtained with GP-302.

No compatibility is obtained with digital audio tape recorders.

3. PRECAUTIONS

3-1) Model and Standard Accessory Check

Check to see that the unit is the one you ordered. See item 8 in this manual for the list of standard accessories.

3-2) Setting Environment

When using the RD-145T, consider environmental conditions such as temperature, humidity, dust, vibration, barometric pressure, magnetic fields, and atmosphere. Please note the following:

- a) When moving the data recorder or tape from a place of low temperature to a place of high temperature, condensation may form around the unit or tape. Wait at least 30 minutes after turning on the power or after checking that there is no dew condensation around the unit and tape before inserting a tape. If a tape with condensation is inserted, the tape may become tangled around the rotary head. Condensation may form if the temperature varies 15°C (59°F) or more per hour irrespective of the humidity being within the specified range.

Note: If the condensation sensor operates, all tape operation LEDs light and tape operation is disabled.

- b) Remove the tape from the data recorder before turning off its power. Turning off the power with a tape inserted may cause the tape to become tangled around the rotary head, if there is any condensation before the power is turned on again.

If the tape becomes tangled around the rotary head, take the appropriate action in section 6 of this manual.

3-3) Input Terminal

The I/O terminal of the data recorder is unbalanced. When the BNC connector cable supplied as an accessory is connected to the I/O terminal of the unit, the outer side of the connector is connected to the frame of the unit. The input impedance is 100 kΩ, the maximum absolute input voltage is ±70 V, and the output impedance is 75 Ω.

When a signal is input to the output terminal, the output amplifier may be damaged.

3-4) Power Supply

The data recorder operates from ac input of 90 to 264 volts or from dc input of 11 to 30 volts. If a power cable which is not supplied as an accessory is used, use one with a small resistance. Since the power supply unit of the RD-145T uses a switching method, excessive current flows from the battery at power-on time. Therefore, use the power suitable for this current.

When using the BU-41 battery unit, optional accessory, mount it securely on the data recorder. Use the optional BU-41-CH battery charger for charging the BU-41. When the dc power supply including the BU-41 battery unit is used in the RD-145T, automatically operates if the voltage drops below approximately 10.2 V, shutting off the power. In this case, turn the POWER switch to the \odot position to prevent the battery from discharging.

To use dc power again, charge the battery so that the correct dc power voltage is obtained and turn the power on.

Note: Under the low voltage protection circuit actuated once, the unit does not operate if dc power is connected with the power switch turned to the \uparrow position. In such a case, turn the power switch to \odot and then \uparrow .

90197540

3A3903

△ 41

3-5) Cassette Tape

a) Designated Tape

We designate DM120 or DM60 manufactured by Hitachi Maxell Co. Ltd. for the RD Series data recorders. Tapes other than those designated may fail to record or reproduce. At worst they may cause unexpected trouble to the unit.

If the designated tapes are not available, contact us.

b) Tape Insertion

When inserting a tape cassette in the cassette compartment, before closing the compartment, always make sure that the tape cassette is pushed in all way. Also, after ejecting a tape cassette, which may cause the tape cassette to be pushed back a little, before closing the cassette compartment, push in the tape cassette all the way.

c) Avoiding BOT (Beginning of Tape) and EOT (End of Tape)

Avoid tape parts near BOT or EOT to ensure recording. That's because near BOT or EOT the connection between the tape and the reel imprints the tape causing dropouts. Especially avoid the last two minutes of the tape where imprints may be severe.

When storing tapes, rewind them to BOT in order not to form imprints near BOT.

3-6) Mounting optional Accessories

Mount the optional accessories after checking the data recorder.

Refer to each specification manual for mounting the optional accessories, GP-302 GPIB interface unit, BU-41 battery unit, and ER-40 remote control unit, etc.

9019754

書き直し要 No. 3A3642

4. APPEARANCE AND FUNCTIONS

4-1) Appearance

4-1-1) Views from three sides

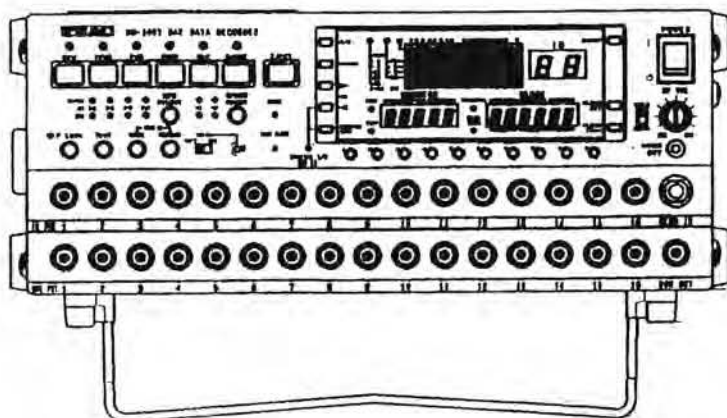
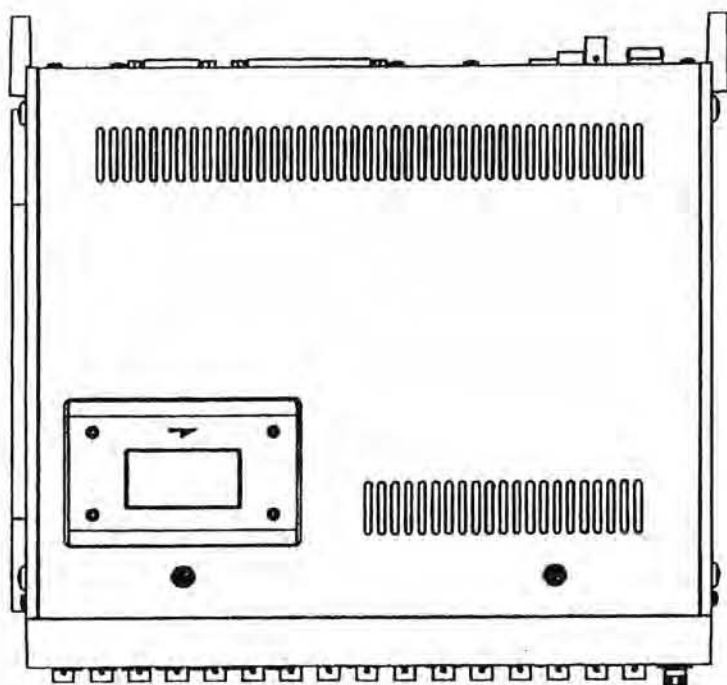
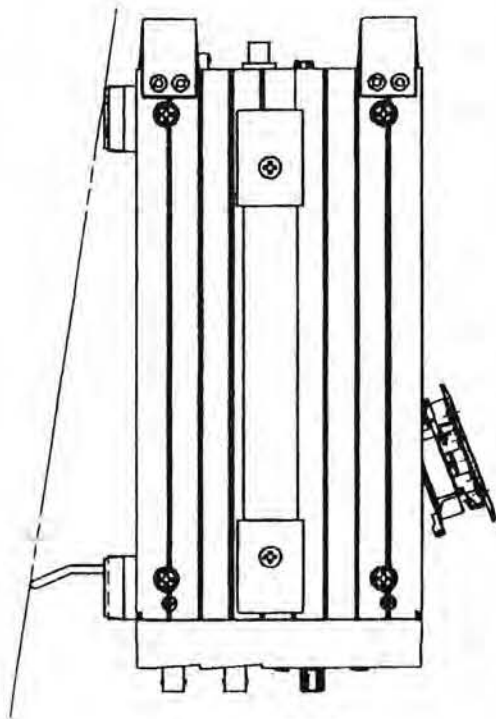

90197542

3A3903

4-2) Reference Numbers

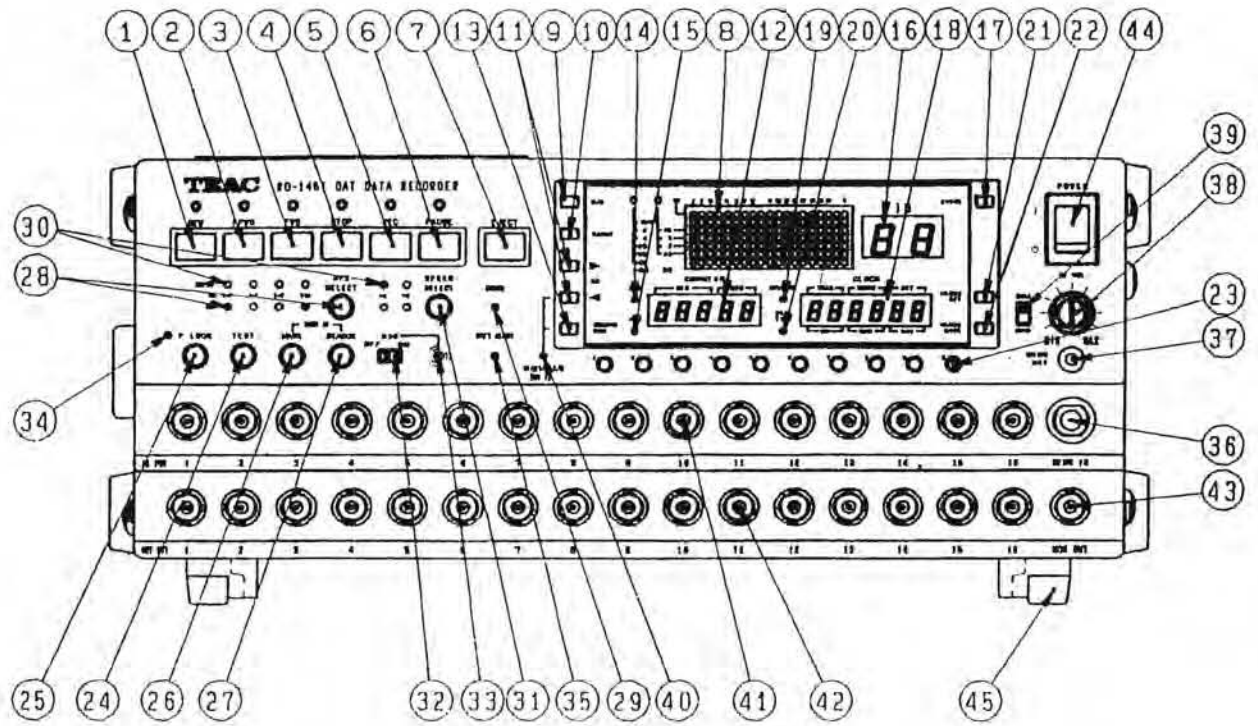

90197543

3A3701

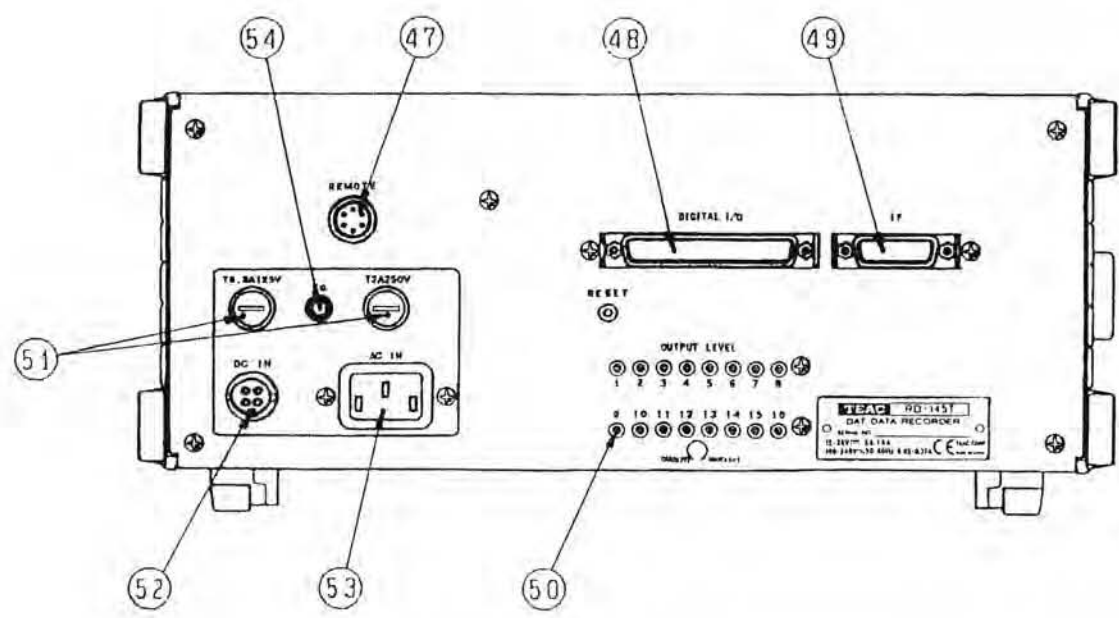
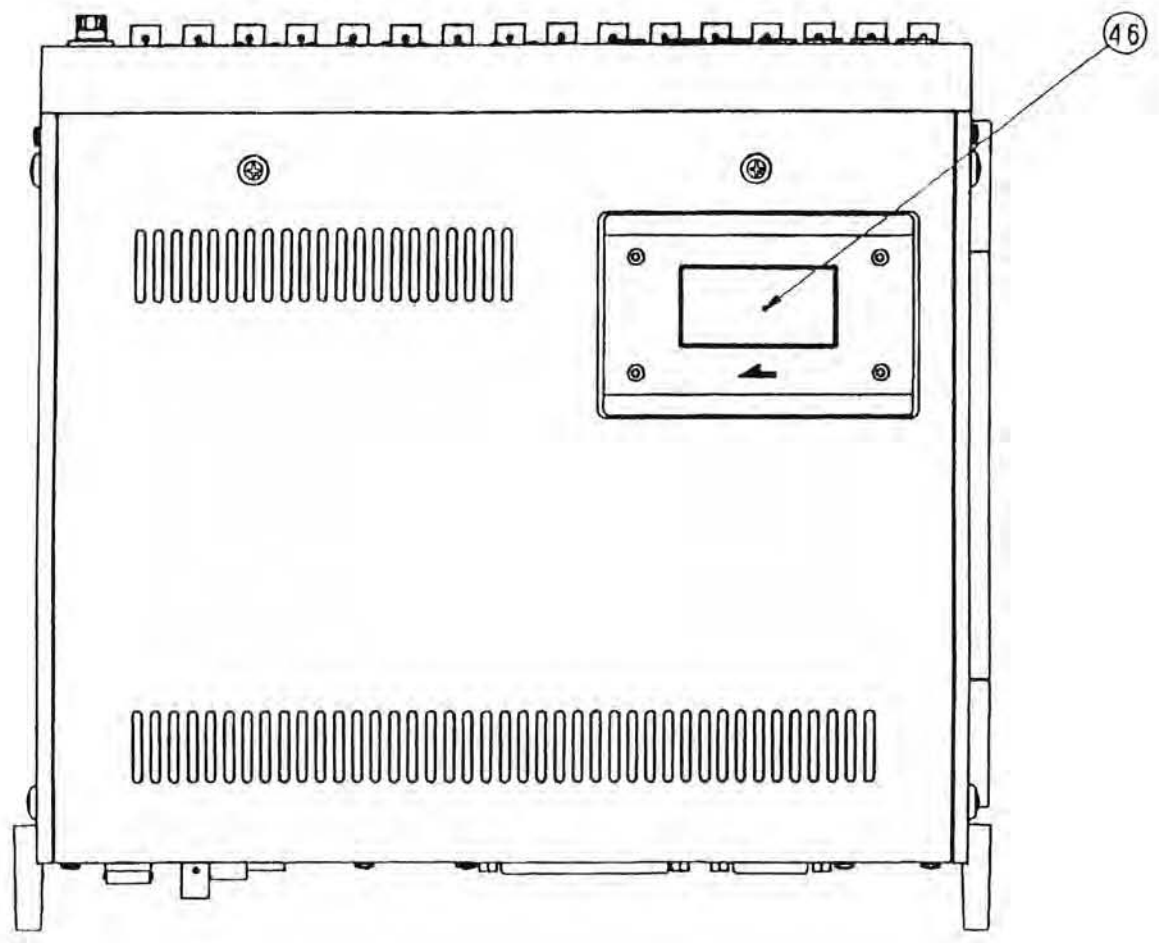

4-3) Names and Functions

| Part No. | Name | Function |
|----------|---|--|
| ① | REW button · LED (Rewind) | <ul style="list-style-type: none"> - Pressing the REW button in the stop mode rewinds the tape. - Pressing the REW button once while in the FWD mode rewinds the tape until the beginning of the data with the currently displayed ID number at high speed then automatically reproduces the tape . In the same way, pressing the REW button more than once consecutively rewinds the tape at high speed to the beginning of the data having the ID number less than that of the current data by the number of times the REW button is pressed minus one, then automatically reproduces the tape. (Note) When the ID number is recorded incorrectly, the above operation may not be performed. - When the REW and ③ FWD buttons are pressed at the same time, the data recorder enters the REVIEW (5-time speed tape running) mode. No reproduction signal is output, however. - LED lights up in REW, REVIEW modes |
| ② | F-FWD button · LED (Fast-forward) | <ul style="list-style-type: none"> - Press the F-FWD button in the stop mode to fast-forward the tape. - Pressing the F-FWD button once while in the FWD mode fast-forwards the tape until the beginning of the data with the ID number next to the currently displayed ID number at high speed then automatically reproduces the tape. In the same way, pressing the F-FWD button more than once consecutively fast-forwards the tape at high speed to the beginning of the data having the ID number greater than that of the current data by the number of times the F-FWD button is pressed then automatically reproduces the tape. (Note) When the ID number is recorded incorrectly, the above operation may not be performed. - When the F-FWD and ③ FWD buttons are pressed at the same time, the data recorder enters the CUE (5-time speed tape running) mode. No reproduction signal is output, however. - LED lights up in CUE, F-FWD modes. |
| ③ | FWD button · LED (Reproduction) | <ul style="list-style-type: none"> - Pressing the FWD button while in the stop mode runs the tape in the forward direction and reproduces the tape . - Setting the ID number with the ② Number buttons in the stop mode then pressing the FWD button searches the tape for the set ID number at high speed then automatically reproduces the tape. (Note) When the ID number is recorded incorrectly, the above operation may not be performed. - LED lights up in FWD, REC FWD, CUE, REVIEW modes. |
| ④ | STOP button · LED (LOAD STOP) (UNLOAD STOP) (Stop) | <ul style="list-style-type: none"> - Pressing the STOP button while in any mode stops the tape running or releases the pause mode and LED lights up. - There are two stop modes: LOAD STOP: When the tape is touching the head UNLOAD STOP: When the tape is not touching the head and the tape has reached its end (Note 1) The data recorder enters the UNLOAD STOP mode after approximately one and half minutes by x2 and 3 minutes by x1 tape speed elapse in the LOAD STOP mode. The STOP LED and 7-segment ID LEDs flash. (Note 2) The UNLOAD STOP mode is for protection of the tape and the head. |

90197545



| Part No. | Name | Function |
|----------|---|---|
| ⑤ | REC button · LED (Recording) | <ul style="list-style-type: none"> - Pressing the REC button while in the stop mode lights LED, causes the REC and PAUSE indicators to light and prepares for recording. After this, pressing the FWD button starts data recording. (Note 1) Pressing the REC and FWD buttons at the same time does not start data recording. (Note 2) The REC and PAUSE indicators flash and the data recorder enters the UNLOAD mode after approximately one and half minutes by x2 and 3 minutes by x1 tape speed elapse in the REC PAUSE mode. Pressing the FWD button in this status starts data recording. (Note 3) When the user presses the FWD button with the REC and PAUSE indicators flashing, the data recorder enters the REC mode after a few seconds. |
| ⑥ | PAUSE button · LED (Pause) | <ul style="list-style-type: none"> - Pressing the PAUSE button while in the REC or FWD mode pauses recording or reproduction. Pressing the FWD button again resumes recording or reproduction. Pressing the PAUSE button while in the FWD mode causes the PAUSE LED only to light. - Pressing the PAUSE button while in the stop mode is equivalent to the pausing while in the FWD mode. (Note) The data recorder enters the stop mode after approximately one and half minutes by x2 and 3 minutes by x1 tape speed elapse in the FWD PAUSE mode. It enters the UNLOAD STOP mode after approximately one and half minutes by x2 and 3 minutes by x1 tape speed elapse. |
| ⑦ | EJECT button (Ejection) | <ul style="list-style-type: none"> - Pressing the EJECT button once while in a mode other than the REC and REC PAUSE modes opens the ④⑥ cassette compartment, enabling the tape to be inserted or removed. (Note) Eject operations are valid only when the power is turned on. |
| ⑧ | MULTI DISPLAY (Bar graph/input range display) | <ul style="list-style-type: none"> - The input ranges or bar meters selected by the ⑨ B/R button are displayed. - In the top row, the monitor channel or the channel for which the input range is to be switched is displayed. - When the bar meters are selected, the I/O levels of all channels and memo announcement are displayed. In the REC PAUSE or REC FWD mode, the input levels are displayed. In the FWD mode, the reproduction levels are displayed. - When the input ranges are selected, the input ranges of all channels are displayed with dots. - CH1 bar meter does not light up when CH1 is in digital input mode (while LED ④⑩ is lighting). |
| ⑨ | B/R button · LED (BAR/RANGE) | <ul style="list-style-type: none"> - This is an alternate switch. This switch selects the input ranges or bar meters for MULTI DISPLAY. When the input ranges are selected, the RANGE LED lights. Pressing the ⑩ RANGE button switches the input range of the channel selected with the ⑪ CH SEL button. When the bar meters are selected, the BAR LED lights. The bar meters are displayed in MULTI DISPLAY so that the user can monitor the input status. |
| ⑩ | RANGE | <ul style="list-style-type: none"> - Pressing this button selects $\pm 0.5/2/5/20$ Vp for the input level of the channel set with CH SEL. This operation is enabled only when RANGE is selected with the ⑨ B/R button. - CH1 range can not be set when CH1 is in digital input mode. |

| Part No. | Name | Function |
|----------|--|--|
| ⑪ | CH SEL | <ul style="list-style-type: none"> - Selects the monitor channel. Specifies a channel for which the input range is to be set with RANGE. The LED corresponding to the specified channel at the top of ⑧ MULTI DISPLAY lights. - During STOP mode, pressing either one of CH SEL buttons and ⑬ COUNTER MODE button at the same time for 3 seconds sets CH1 digital input mode and ⑩ LED lights up. Pressing the buttons again at the same time for 3 sec returns the mode to normal analog input mode. - With the CH1 digital input mode selected, the CH1 can not be selected as a monitor channel. |
| ⑫ | COUNTER (Minutes/seconds display) | <ul style="list-style-type: none"> - Displays the minutes and seconds which are recorded on the tape. Alternatively, displays the minutes and seconds which have been recorded on the tape. - The maximum display is 199 minutes and 59 seconds. (Note) If a tape is used which has no counter value recorded in each mode, nothing may be displayed. |
| ⑬ | MODE SW button (A-P mode switching) | <ul style="list-style-type: none"> - Switches the counter display between the ABS (Absolute) and PGM (Program) modes. - During STOP mode, pressing either one of ⑪ CH SEL buttons and MODE button simultaneously for 3 seconds, the unit enters CH1 digital input mode and ⑩ LED lights up. Pressing the buttons again for 3 sec, the unit returns to the normal analog input mode. |
| ⑭ | ABS (Absolute) LED (Absolute time) | <ul style="list-style-type: none"> - When the LED lights, the absolute time from the beginning of the tape (BOT) is displayed on the ⑫ COUNTER. (Note 1) The value displayed on the A counter disappears after a gap between data when data is recorded discontinuously on a tape or the data is reproduced. (Note 2) When a program is recorded at a speed of x2, a value of twice the recording time is recorded. <p>Beginning of tape (BOT)</p> |
| ⑮ | PGM (Program) LED (Program time) | <ul style="list-style-type: none"> - When the LED lights, the time from the beginning of data (BOT) for each ID number is displayed on the ⑫ COUNTER. (Note) When a program is recorded at a speed of x2, a value of twice the recording time is recorded. |

90197548

| Part No. | Name | Function | | | | | | | | | | | | |
|---|---|---|------------|---------------|---|-------------------------------|---------------------------|-------------------------------|----|---|---|---------|---------------------------------|---------------|
| ⑩ | ID (Data number display) | <ul style="list-style-type: none"> - Displays the data number. - Displays the following in addition to the data number <table border="1" data-bbox="603 277 1385 584"> <thead> <tr> <th>ID display</th> <th>Status</th> </tr> </thead> <tbody> <tr> <td>00 flashing</td> <td>Tape being loaded or unloaded</td> </tr> <tr> <td>AA</td> <td>Unrecorded tape</td> </tr> <tr> <td>bb</td> <td>On the lead-in tape for five seconds from BOT</td> </tr> <tr> <td>No display</td> <td>No tape</td> </tr> <tr> <td>EE</td> <td>On the E MARK</td> </tr> </tbody> </table> <ul style="list-style-type: none"> - When the data recorder enters the REC PAUSE or REC FWD mode from the beginning of the tape, the tape automatically runs with ID number bb displayed for approximately five seconds. The data recorder then pauses recording in the REC PAUSE mode or records ID numbers starting at 01 in the REC FWD mode. - When recording ID numbers on an unrecorded tape, numbering automatically starts at 01. An arbitrary number cannot be set. - In each REC FWD mode, the ID number is incremented by one before it is recorded. - For nine seconds (x1 speed) and 4.5 seconds (x2 speed) after the ID number changes, the decimal point of each digit in the display flashes. | ID display | Status | 00 flashing | Tape being loaded or unloaded | AA | Unrecorded tape | bb | On the lead-in tape for five seconds from BOT | No display | No tape | EE | On the E MARK |
| ID display | Status | | | | | | | | | | | | | |
| 00 flashing | Tape being loaded or unloaded | | | | | | | | | | | | | |
| AA | Unrecorded tape | | | | | | | | | | | | | |
| bb | On the lead-in tape for five seconds from BOT | | | | | | | | | | | | | |
| No display | No tape | | | | | | | | | | | | | |
| EE | On the E MARK | | | | | | | | | | | | | |
| ⑪ | EVENT SW | <ul style="list-style-type: none"> - Pressing the EVENT switch button while in the REC FWD mode increments the ID number by one. - It takes about nine seconds (4.5 seconds at x2 speed) to record an ID number. While recording the ID number, the EVENT switch button is disabled. | | | | | | | | | | | | |
| ⑫ | CLOCK (Clock/calendar display) | <ul style="list-style-type: none"> - Displays the time (hours, minutes, and seconds) or the calendar (year, month, and day). <table border="1" data-bbox="595 1234 1393 1610"> <tbody> <tr> <td rowspan="2">FWD</td> <td>Recorded tape</td> <td>Displays the reproduction time on the tape.</td> </tr> <tr> <td>Unrecorded tape</td> <td>Nothing may be displayed.</td> </tr> <tr> <td>F-FWD REW STOP PAUSE</td> <td></td> <td>Previous state</td> </tr> <tr> <td>REC PAUSE REC FWD During power-on</td> <td></td> <td>Displays the time in real time.</td> </tr> </tbody> </table> <p>(Note) When the MPX ERR indicator lights or a tape which was recorded incorrectly is reproduced, a hit-or-miss display may occur or nothing may be displayed. This is not an error, however.</p> | FWD | Recorded tape | Displays the reproduction time on the tape. | Unrecorded tape | Nothing may be displayed. | F-FWD REW STOP PAUSE | | Previous state | REC PAUSE REC FWD During power-on | | Displays the time in real time. | |
| FWD | Recorded tape | Displays the reproduction time on the tape. | | | | | | | | | | | | |
| | Unrecorded tape | Nothing may be displayed. | | | | | | | | | | | | |
| F-FWD REW STOP PAUSE | | Previous state | | | | | | | | | | | | |
| REC PAUSE REC FWD During power-on | | Displays the time in real time. | | | | | | | | | | | | |
| ⑬ | CALENDAR LED | <ul style="list-style-type: none"> - While the LED lights up, the year, month, and day are displayed on the ⑫ CLOCK. | | | | | | | | | | | | |
| ⑭ | REAL TIME LED (Clock real time indicator) | <ul style="list-style-type: none"> - While the LED lights up, hours, minutes, and seconds are displayed on the ⑫ CLOCK. | | | | | | | | | | | | |

| Part No. | Name | Function |
|----------|---|---|
| ⑳ | CLOCK SET | <ul style="list-style-type: none"> - When the user presses the ㉑ MODE SW button <u>three or more seconds</u>, the 7-segment LED of the least significant digit in the CALENDAR (year, month, and day) or REAL TIME (hours, minutes, and seconds) mode starts flashing. Enter the year, month, and day or hours, minutes, and seconds with the ㉑ number buttons from 0 to 9. - Press the ㉒ CLOCK button after entering the desired numbers with the ㉑ number buttons. Then the time setting is complete. |
| ㉑ | MODE SW (CALENDAR-REAL TIME mode selector switch) | <ul style="list-style-type: none"> - Used to switch the ㉒ CLOCK display between the CALENDAR (calendar) and REAL TIME (clock) modes. LEDs ㉓ or ㉔ shows which mode is selected. |
| ㉒ | Number buttons (1, 2, ..., 9, 0) | <ul style="list-style-type: none"> - Used to search a tape on which ID numbers are recorded for an ID or set the calendar clock. |
| ㉓ | TEST (Test signal generator) | <ul style="list-style-type: none"> - Generates a test signal of about 50% at 1 kHz. - A test signal is output while the TEST button is held down in the REC PAUSE or REC FWD mode. - Can be used for checking the E-E (A/D → D/A) function during recording or for a simplified check of the record/reproduction function during reproduction. - With the CH1 digital input mode selected, CH1 can not be inputted. |
| ㉔ | P LOCK | <ul style="list-style-type: none"> - When the ㉕ LOCK indicator flashes, then lights by pressing the P LOCK switch three or more seconds, all switches are locked. - When the ㉕ LOCK indicator flashes, then goes off by pressing the P LOCK switch three or more seconds, the switches are unlocked. |
| ㉕ | E MARK | <ul style="list-style-type: none"> - Pressing this button <u>three or more seconds</u> in the REC PAUSE mode writes an E mark. (Note 1) For details, see Section 5-11, "End Search" on page 25. (Note 2) No recording can be performed on any E mark. (Note 3) No E mark can be written following an unrecorded portion or in a range within nine seconds (4.5 seconds at x2 speed) from an ID change. |
| ㉖ | E SEARCH (End search) | <ul style="list-style-type: none"> - Pressing this button performs REW, searches a tape for the end of recording or a recorded E mark from BOT at a high speed, and stops tape running. - Pressing this button three seconds in the STOP mode performs the above operation. |
| ㉗ | MPX SELECT button · LED CH1-2 CH1-4 CH1-8 CH1-16 | <ul style="list-style-type: none"> - Switches the number of channels used for recording. The LEDs for recording light as follows. This switch is disabled during recording. When this switch is set to CH1 to 2, signals can be input to or output from the first and second channels. When the switch is set to CH1 to 4, signals can be input to or output from the first through fourth channels. When the switch is set to CH1 to 8, signals can be input to or output from the first through eighth channels. When the switch is set to CH1 to 16, signals can be input to or output from the first through sixteenth channels. |

| Part No. | Name | Function |
|----------|---|--|
| ⑳ | MPX REP ERROR LED (Data reproduction error) | <ul style="list-style-type: none"> - Lights when a data error occurs in the REC FWD or FWD mode resulting from a damaged tape, recording malfunction, reproduction malfunction, or clogged head. - Lights when a tape which was recorded by the audio tape recorder such as audio R-DAT is reproduced. <p>(Note) This indicator lights when an unrecorded tape is reproduced. The status of this indicator remains unchanged until the next reproduction.</p> |
| ㉑ | MPX REPRO LED CH1-2 CH1-4 CH1-8 CH1-16 SPEED LED x2 x1 | <ul style="list-style-type: none"> - MPX display during reproduction - If two channels are selected during recording, the CH1 to 2 indicator automatically lights in the FWD mode. - If four channels are selected during recording, the CH1-4 indicator automatically lights in the FWD mode. - If eight channels are selected during recording, the CH1-8 indicator automatically lights. - If sixteen channels are selected during recording, the CH1-16 indicator automatically lights. <p>(Note) When tape containing no record is reproduced, all indicators light. Even when reproduction is completed, these lights remain on until the next reproduction start.</p> <ul style="list-style-type: none"> - Shows recording speed of a reproduced tape. x2 LED lights up automatically when a tape recorded at x2 speed is used and x1 LED lights up automatically when a tape recorded at x1 speed is used. <p>(Note 1) Reproduction tape speed will be set with ㉒ SPEED SELECT.</p> <p>(Note 2) The display is not defined during error display ㉑.</p> <p>(Note 3) The display is stored after completion of the reproduction.</p> |
| ㉒ | SPEED SELECT button · LED x2 x1 | <ul style="list-style-type: none"> - Sets tape speed for recording and reproduction. The setting will be made under STOP mode or no tape loaded. |
| ㉓ | Microphone SW | <ul style="list-style-type: none"> - When this switch is on with no external microphone connected, the microphone built in the main unit is on. - When this switch is on with an external microphone connected, the built-in microphone is off and the external microphone is on regardless of whether the press talk SW on the external microphone is on. - When this switch is off, the built-in microphone is off. The external microphone operates depending on whether the press talk SW is on. <p>(Note) When an external microphone is connected to the optional ER-40 remote control unit, the setting of the built-in microphone SW on the main unit does not work.</p> |
| ㉔ | Microphone hole | <ul style="list-style-type: none"> - Hole for the built-in microphone |
| ㉕ | LOCK LED | <ul style="list-style-type: none"> - Lights up in the panel lock status. |

| Part No. | Name | Function | | | | | | | | | | |
|----------------------|--|---|------|----------|------|-----|-----|-------------|----------------------|--|--------------|-----|
| ③⑤ | BATT ALM (Voltage alarm indicator) | - Flashes when the voltage is 11 V or less when the dc power or optional battery unit is used. | | | | | | | | | | |
| ③⑥ | MEMO IN | - Used when the memo sound is input with the microphone supplied as an accessory. - When the microphone jack is plugged into the MEMO IN connector, the built-in microphone is automatically disconnected and memo sound can be input via the external microphone only. | | | | | | | | | | |
| ③⑦ | MEMO OUT (Earphone output) | - Used to hear the memo sound or data sound from the earphone. - When the earphone is plugged into the MEMO OUT jack, the sound from the speaker is disconnected. | | | | | | | | | | |
| ③⑧ | SP VOL | - Volume control of the speaker and the earphone. | | | | | | | | | | |
| ③⑨ | DATA/MEMO | - DATA/MEMO selection switch. Selects MEMO sound or DATA sound and outputs it through a speaker or earphone. | | | | | | | | | | |
| ④① | CHI/DIO LED | - Lights up when CHI is set to digital mode. The LED also lights up when a tape recorded with digital input mode is reproduced and the unit enters the digital mode. - CHI digital input mode is set by pressing either one of ①① CH SEL buttons and ①③ COUNTER MODE button at the same time for more than 3 sec. Pressing the buttons again at the same time for more than 3 sec releases the digital input mode and returns the unit to the analog input mode. - CHI of ⑧ MULTI DISPLAY does not light up when the LED is turned on. Moreover, CHI can not be selected as a monitor channel. - When the LED is turned on, CHI can not use the ④① ④② BNC I/O connectors. Use ④⑧ DIGITAL I/O connector on the rear panel in this case. | | | | | | | | | | |
| ④① | INPUT (Input connector) | - Input connector - The input voltage range is ± 0.5 V, ± 2 V, ± 5 V, or ± 20 V (maximum). - CHI does not accept its input when the digital input is selected. | | | | | | | | | | |
| ④② | OUTPUT (Output connector) | - Output connector - The output level can be adjusted with ⑤① Volume control on the rear panel. - The output is not fed to CHI when ④① CHI/DIO LED is lights up. | | | | | | | | | | |
| ④③ | MONI OUT (Monitor output) | - The output of the channel selected by the channel selector switch is as follows: <table border="1" data-bbox="603 1563 1378 1850"> <thead> <tr> <th>Mode</th> <th>MONI OUT</th> </tr> </thead> <tbody> <tr> <td>STOP</td> <td>0 V</td> </tr> <tr> <td>FWD</td> <td>Tape output</td> </tr> <tr> <td>REC FWD REC PAUSE</td> <td>E-E (Λ/D \rightarrow D/Λ) output</td> </tr> <tr> <td>F-FWD REW</td> <td>0 V</td> </tr> </tbody> </table> | Mode | MONI OUT | STOP | 0 V | FWD | Tape output | REC FWD REC PAUSE | E-E (Λ /D \rightarrow D/ Λ) output | F-FWD REW | 0 V |
| Mode | MONI OUT | | | | | | | | | | | |
| STOP | 0 V | | | | | | | | | | | |
| FWD | Tape output | | | | | | | | | | | |
| REC FWD REC PAUSE | E-E (Λ /D \rightarrow D/ Λ) output | | | | | | | | | | | |
| F-FWD REW | 0 V | | | | | | | | | | | |

90197552

3A3903

書

| Part No. | Name | Function |
|----------|--------------------------------------|---|
| ④④ | POWER (Power switch) | - This is a rocker switch. Pressing the upper side (I) of this switch turns on the power. Pressing the lower side (Ⓟ) of this switch turns off the power. |
| ④⑤ | Rubber foot with stand | - Pulling out the stand enables the front of the data recorder to incline about 10°. |
| ④⑥ | CASSETTE COMPARTMENT | - Pocket for inserting and removing the tape - Pressing the EJECT button when the power is supplied opens the cassette compartment, enabling the tape to be inserted or removed. - Push the cassette compartment securely enough to close and lock it. |
| ④⑦ | REMOTE | - For use with the optional ER-40 remote control unit. - The switches on the data recorder are operable even during use of the ER-40. - The switches on the data recorder are valid when both the switches on the data recorder and the ER-40 are pressed at the same time. |
| ④⑧ | DIGITAL I/O Connector (D Sub 37P) | - Accepts digital input and outputs digital signal when CHI is in digital input mode. - Effective only when ④⑩ CHI/DIO LED is on. |
| ④⑨ | I/F connector for GP-302 | - When optional GPIB Unit (GP-302) is used, the connector of GP-302 is connected to this connector. |
| ⑤⑩ | OUTPUT LEVEL | - Adjusts output voltage at the ④⑫ OUTPUT connector. - Adjusted to develop 2 Vp at 100% input when the control is fully turned in counterclockwise direction. - Max 5 Vp available. |
| ⑤① | Fuse holder | - On each holder, a fuse for ac or dc power is mounted. |
| ⑤② | dc power input connector | - Connected to the cable during the use of dc power. - Also connected to the connector of the optional BU-41 battery unit. |
| ⑤③ | ac power input connector | - Connected to the cable during the use of ac power. |
| ⑤④ | FG (Frame Ground) | - Grounding terminal |

5. OPERATION METHOD

5-1) Basic Operation

Perform the following operations and checks according to the steps below:

| Step | Precautions and display of this unit |
|--|--|
| 1) Connect the power cable. | Be sure to check whether the input power conforms to the specified voltage. |
| 2) Turn the power on. | Display of this unit COUNTER Off ID Off CLOCK Year, month, day or hour, minute and second display MODE CALENDAR or REAL TIME If the BATT ALM lights, increase the dc power-supply voltage. |
| 3) Press the EJECT button. | The cassette compartment is opened. ID 00 flashes or is off. |
| 4) Insert a cassette tape. | Insert a cassette tape so that the direction of its arrow matches that of the arrow on the cover of the cassette compartment. (Use a new cassette tape starting at the beginning of the tape.) Always push the tape cassette into the cassette compartment all the way. Refer to 3-5) "Cassette Tape" on page 5. |
| 5) Press down the cassette compartment. | Press the cassette compartment until it locks. |
| 6) Automatic tape loading | After the tape is loaded automatically, it touches the head and runs a little. COUNTER Off ID 00 CLOCK Calendar or time display |
| 7) Press the REC button. | The REC and PAUSE indicators light. (Preparation for recording is complete.) ID bb REC } PAUSE } These indicators flash for about five seconds. |
| 8) Press the FWD button. | Recording starts the moment the REC and FWD indicators light. COUNTER Recording elapsed time display (common to both ABS and PGM modes) (Note 1) The COUNTER shows a real time when a recording is made at speed of x1. However, time is counted at a rate of twice the real time when the recording is made at speed of x2. That is, the counter shows a time converted into a time equivalent to the speed of x1. ID 01 CLOCK Calendar or time display |
| Approx. 60 seconds (Press the TEST button.) | (When the TEST button is pressed, this unit records 1 kHz and approx. 50% test signal. Bar meter: The last three dots are turned on for each channel. For channel M (memo) ambient sound level is indicated. Generation of the test signal stops when the TEST button is released.) |





90197553

3A3703

品質

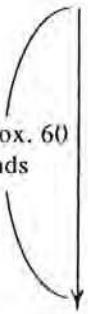
品質

90197554

| Step | Precautions and display of this unit |
|---|--|
| 9) Press the PAUSE button.  | The tape stops running temporarily the moment the REC and PAUSE indicators light. COUNTER Stops. ID 01 CLOCK Calendar or time display |
| 10) Press the FWD button.  Approx. 60 seconds | Recording restarts the moment the REC and FWD indicators light. COUNTER ABS Displays continuously. PGM Elapsed recording time indication beginning with 000. (Note 1) The COUNTER shows a real time when a recording is made at speed of x1. However, time is counted at a rate of twice the real time when the recording is made at speed of x2. That is, the counter shows a time converted into a time equivalent to the speed of x1. ID 02 CLOCK Calendar or time display |
| 11) Press the PAUSE button.  Repeats recording operation (approx. 60 seconds for each operation) in steps 8) and 9) until the ID number reaches 10. | Conforms to step 9). ID 02 03 09 10 |
| 12) Press the STOP button.  | The tape stops running. COUNTER Stops. ID 10 CLOCK Calendar or time display |
| 13) Press the REW button.  | The unit rewinds the tape to the beginning and stops automatically. Operation during tape rewind: COUNTER Displays the counter value recorded in the tape. ID Displays the ID value recorded in the tape. CLOCK Calendar or time display When the tape is stopped: COUNTER Off ID 00 CLOCK Calendar or time display |



90197555

Step

Precautions and display of this unit

14) Press the FWD button.

This unit reproduces the contents recorded from the beginning of the tape.

COUNTER

ABS: Continuous minute and second display from 000 (beginning of tape)

(Note 2) A real time is displayed when a recording is made at speed of x1. However, when a recording is made at speed of x2, the time is displayed as twice the real time.

PGM: Minute and second display from 000 whenever recording starts.

(Note 2) A real time is displayed when a recording is made at speed of x1. However, when a recording is made at speed of x2, the time is displayed as twice the real time.

ID Displays 01 to 10.

CLOCK

CALENDAR: Displays the recorded year, month, and date.

REAL TIME: Displays the recorded hour, minute, and second.

Bar meter

Each channel: Displays the value of the recorded signal
M (memo) channel: Displays the level of the recorded ambient sound.

SP VOL: DATA/MEMO selector switch enables the sound recorded in the memo channel or data sound of the channel selected by CH SEL to be heard

MONI OUT

Outputs data of the data channel selected by CH SEL.

MEMO OUT

The data can be listened to using the earphone, in which case the speaker is disconnected.



5-2) Input Connections and Tape Speed, CH MPX, and Setting of Input Range

Connect the I/O cable supplied with the unit to the INPUT connector and connect a signal corresponding to each channel cable.

With the tape speed X1 selected, RD-145T accepts inputs through CH1-CH2, CH1-CH4, CH1-CH8, CH1-CH16, and the channels can be switched with the MPX SELECT button (CH1-2/CH1-4, CH1-8/CH1-16). Recording frequency is DC to 20kHz for each channel when CH1-2 mode is selected, DC to 10kHz when CH1-4 mode is selected, DC to 5kHz when CH1-8 mode is selected and DC to 2.5kHz when CH1-16 mode is selected respectively.

With the tape speed X2 selected, RD-145T accepts signals through CH1-CH4, CH1-CH8 or CH1-CH16, and the recording frequency corresponding to above channels are DC to 20kHz, DC to 10kHz or DC to 5kHz, respectively. Select the tape speed and CH MPX according to your purpose.

- **Setting of tape speed**
Set the tape speed with the SPEED SELECT button before loading a tape or in the STOP mode. The selected tape speed is shown with a LED just upper the SPEED SELECT button. Recording or reproduction will be made at the tape speed set.
Note: The speed setting is only enable in the STOP mode or no tape loaded.
- **Setting of CH MPX**
Set a channel MPX with the MPX SELECT button. The content set is shown on a REC CH1-2, REC CH1-4, REC CH1-8, and REC CH1-16 LED.
Note: The setting can not be made in the REC FWD mode. The CH1-2 can not be set when the tape speed is set to X2.
- **Input range setting**
Select one of 0.5V, 2V, 5V, and 20V RANGES depending on an input signal voltage. Press B/R button to set the RANGE mode (R side LED lights up) and then select a desired channel with the CH button and CH display. Next, select a desired range 0.5V, 2V, 5V, or 20V with the RANGE button. Select a next channel with the CH button and then select a desired range in the same way.
After completion of the setting, change the display mode to the bar meter display (B side LED lights up) by pressing the B/R button. Press the REC button and check the input level under the REC PAUSE condition. Each value for the input RANGE is a \pm maximum value. A voltage higher than this value will cause signal saturation, so care will be necessary. Always set the range so that OVER (uppermost of the bar meter) does not light up.
Note: The RANGE setting can be made during REC FWD.

5-3) Output Connection and Level Adjustment

The output connectors develop the input signals in the REC PAUSE and REC FWD modes and the tape reproduction signals in the FWD mode. Connect the connector to other equipment using the I/O cable supplied with the unit.

Note: No output is available in a mode other than REC PAUSE, REC FWD, and FWD.

- **Output level adjustment**
The output level can be adjusted within a range of $\pm 2V_{\text{peak}}$ to $\pm 5V_{\text{peak}}$ with the OUTPUT LEVEL control on the rear panel. Since a DC OUTPUT CAL signal is obtained in the STOP mode as in the following ① and ②, it can be used for the output voltage adjustment or to check input level for other equipment.
- ① Press the TEST button and P LOCK button simultaneously in the STOP mode and a DC voltage corresponding to +100% input will be obtained.
 - ② Press the TEST button and E MARK button simultaneously in the STOP mode and a DC voltage corresponding to -100% input will be obtained.

The output level has been adjusted to develop 2V peak when 100% input enters with the OUTPUT LEVEL control turned in fully counter-clockwise direction until clicks are heard.

5-4) Memo (Announcement) Recording or Reproduction

This unit is equipped with a built-in microphone, so that it always records its ambient sound automatically when the user presses the REC and FWD buttons with the MIC ON/OFF switch on. The microphone provides the AGC control facility so that recording can be made at an appropriate level. The bar meter at mark M shows the input level of the microphone.

When recording sound using an external microphone, plug the external microphone into the MEMO IN connector. The microphone picks up sound when the user presses the press talk switch. When the MIC ON/OFF switch is on, the microphone picks up sound regardless of the status of the press talk switch. The built-in microphone is disconnected automatically when an external microphone is used. When there is no memo to be recorded, the MIC ON/OFF switch must be turned off.

The speaker is used to reproduce the sound. When the user plugs the earphone into the MEMO OUT connector, the speaker is disconnected.

5-5) Data Sound Monitoring

The user can listen to the input sound or the output sound reproduced from the tape in this unit. When the DATA/MEMO switch is set to DATA, the current mode is changed to the data monitoring mode. Then, select a channel with the CH SEL switch.

Monitoring the input sound is permitted during REC PAUSE or REC FWD.

5-6) ID Recording and Reproduction

- a) An ID number is recorded automatically when data recording is made. An arbitrary ID number cannot be recorded, however.
- b) When REC PAUSE (REC FWD) is performed at the beginning of the tape (BOT), it runs automatically for about 5 seconds with the ID indicator flashing with bb.
- c) When recording is performed after automatic recording at BOT ends, the ID number always begins with 01 and is incremented by one at every recording operation unless the tape is advanced over unrecorded tape during recording. (See Fig. 1.)
- d) If there is an unrecorded portion of tape during continuous recording, and the power is turned off, the ID number for the next recording is 01. (See Fig. 2.)
- e) Pressing the EVENT switch once during continuous recording increments the ID number by one and the number is recorded. This causes a start ID to be recorded for approximately 9 seconds (x1 tape speed) and 4.5 seconds (x2 tape speed), during which the decimal point of each digit in the ID number display flashes and the EVENT button cannot increment the ID number.
(To enable a normal search operation to be performed record for approximately 60 seconds or more for each ID.) (See Fig. 1.)
- f) The ID number can be used as a search number for finding the start of each recording portion as well as a recording number or file number. For the ID number to be used as a search number, the recording for that ID number must be approximately 60 seconds or more and there must not be any unrecorded portion on the tape. If the recording is short or discontinuous, the normal search may not be performed. (See Fig. 1.)
- g) When a recorded tape is used midway for recording, the unit reads and displays the ID number of the recorded portion.
Recording then starts from the portion with the ID number of [display value +1] after REC FWD is performed. (See Fig. 2.)
- h) When an attempt to continue an ID number by eliminating the unrecorded portion as shown in Fig. 2, rewind the tape, stop it just before the end of the portion with ID number 12, and perform REC FWD.

90197557



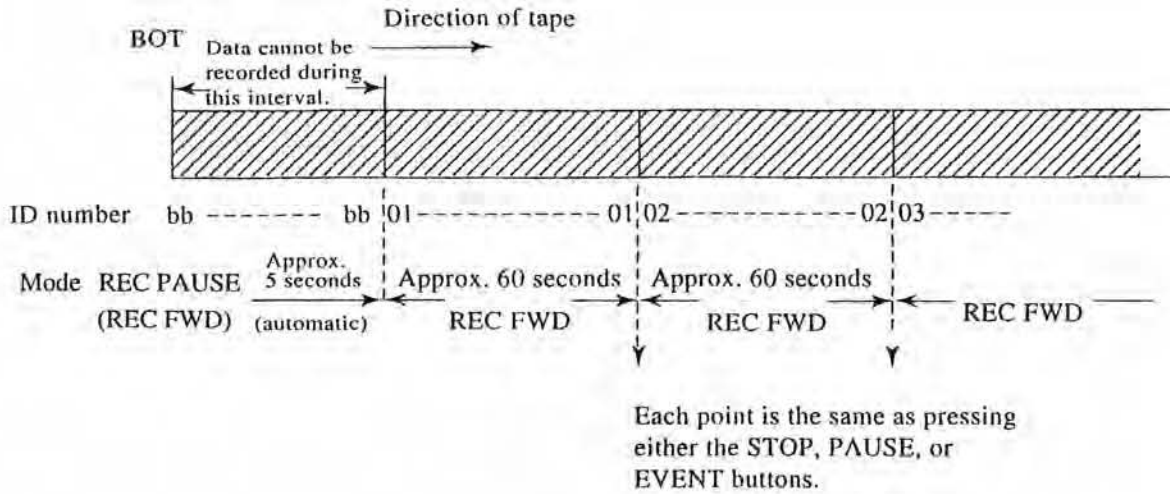

Fig. 1

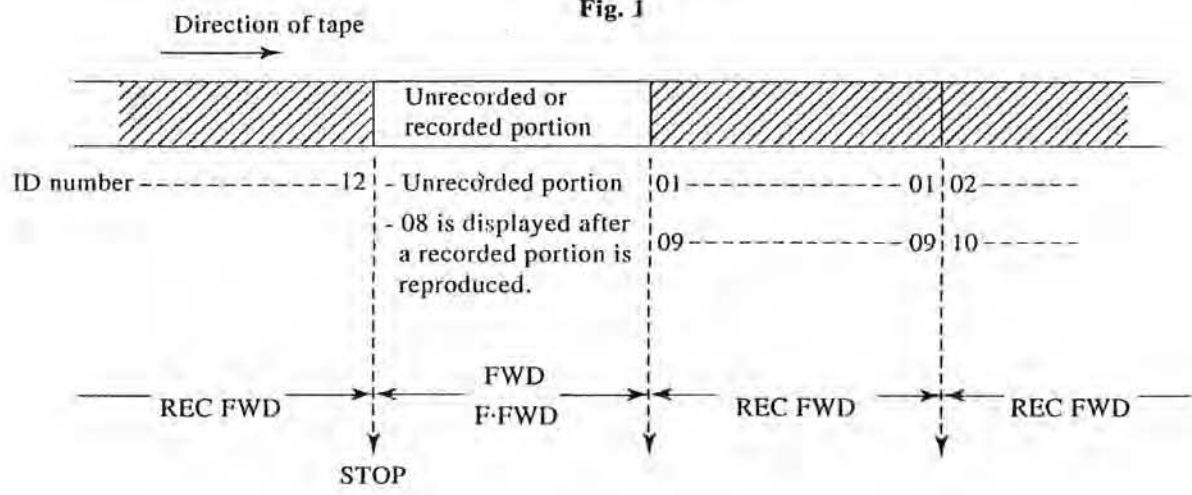

Fig. 2

5-7) Recording with the Counter

- a) The counter value is displayed in minutes and seconds (M,S), and is recorded automatically when data recording is made. Arbitrary counter values cannot be recorded.
- b) When REC PAUSE (REC FWD) is performed at BOT, the tape runs automatically for approximately 5 seconds without any display. (Fig. 3)
- c) The ABS mode or the PGM mode is used for displaying the counter.
- d) A continuous counter value is recorded when continuous recording is made in the ABS mode. If unrecorded tape is used. The counter ABS value disappears after continuous recording stops. (Fig. 3)
- e) If a recorded tape is used to record data, this unit automatically reads the counter value of the previous recording and starts recording the counter value following that value when the cassette tape is loaded. (Fig. 4)
- f) The PGM mode value is recorded beginning with 00000 whenever a recording is made or the ID number is incremented by pressing the EVENT button.
- g) When a recording is made at speed of x1, the counter value is recorded as a real time. However, when the recording is made at speed of x2, a value of twice the real time is recorded. So, multiply 1/2 to the time when reading the time in terms of x2 speed.

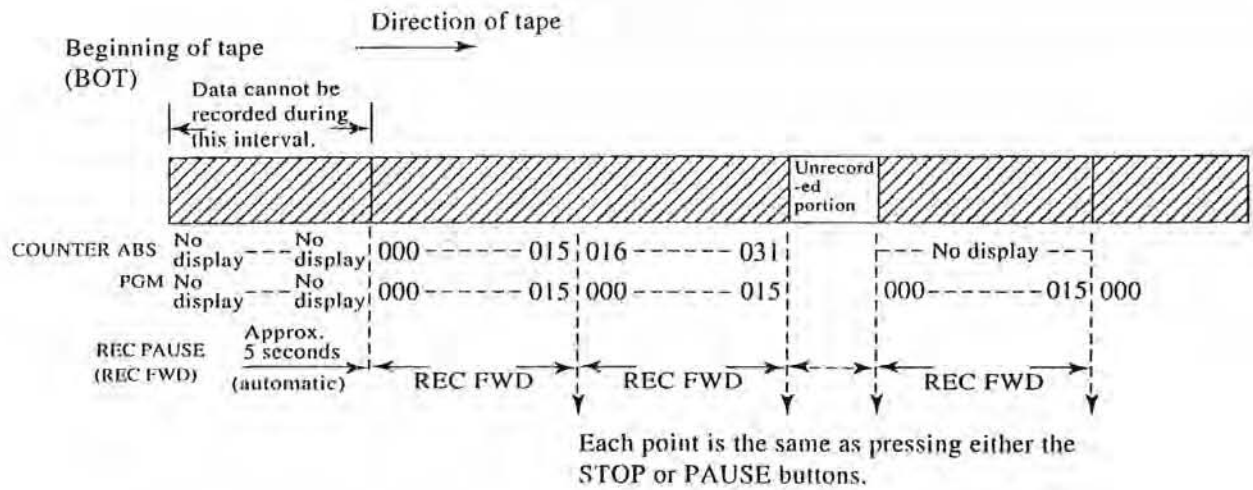

Fig. 3

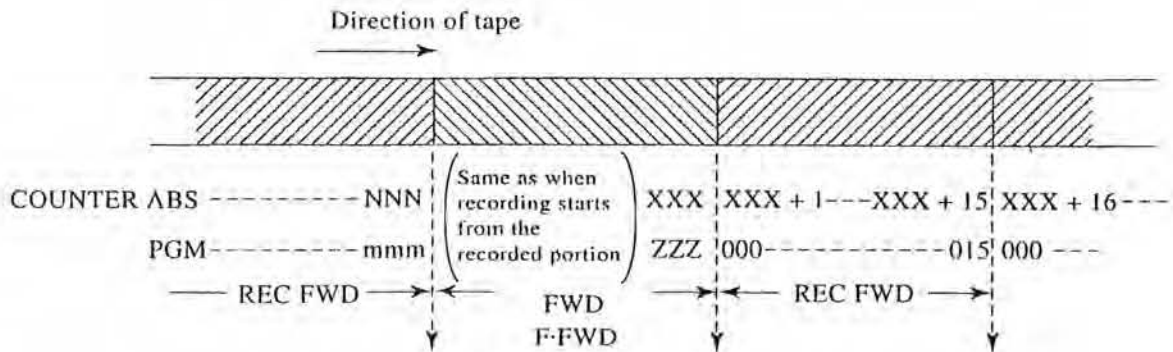

Fig. 4

5-8) CLOCK Recording

- a) The clock value is recorded automatically when data is recorded.
- b) Adjusting the two-digit of the year, month, and day

Press the MODE button to turn the CALENDAR LED on. Press the CLOCK SET button three or more seconds to put the recorder in the calendar adjustment mode. Enter the desired year, month, and day with the number buttons, then press the CLOCK SET button again to set the year, month, and day.

- c) Adjusting the two-digit of the hours (00 to 24), minutes, and seconds

Press the MODE button to turn the REAL TIME LED on. Press the CLOCK SET button three or more seconds to put the recorder in the time adjustment mode. Enter the desired hours, minutes, and seconds with the number buttons, then press the CLOCK SET button again to set the hours, minutes, and seconds.

5-9) Reproduction Tape Speed Setting

Reproduction tape speed can be set with the SPEED SELECT button regardless of the recording tape speed. So, data processing will be made at two times the recording speed or a recorded tape will be reproduced at a half speed of the recording.

Recorded tape speed is displayed with the REPRO SPEED X2/X1 LEDs. Select a tape speed according to your purpose.

Note: SPEED SELECT is enable in the STOP and EJECT modes only.

5-10) Search Operation

- a) This unit can perform high-speed search with an ID number.
- b) To enable the unit to perform normal search operation, as shown in Fig. 1, continuous recording must have been made and one ID number must be recorded about 60 seconds or more.
- c) When the desired ID number has been located, the unit automatically starts FWD reproduction.
- d) When the PAUSE button is pressed during searching, the unit enters the PAUSE mode (not the FWD mode), after finding beginning of the data.

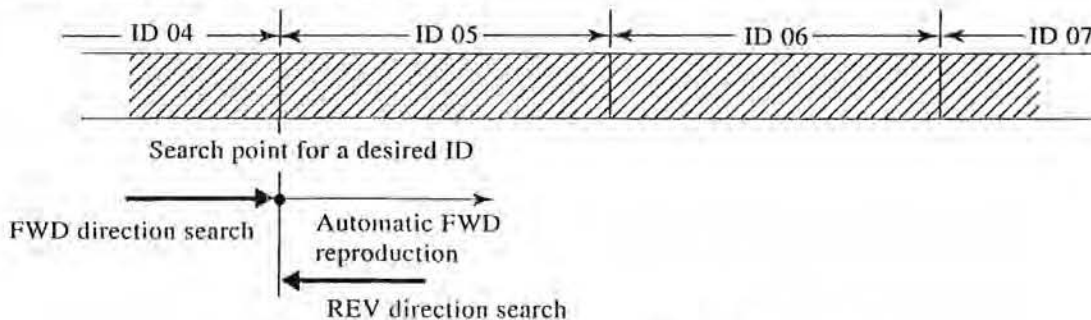

Fig. 5 Searching the tape for ID 05

Search method:

- 1) Enter the desired ID number (01 to 99) with the number buttons from 0 to 9 in the STOP mode. Press the FWD button, and the tape is automatically advanced to the entered number at a high speed. When the entered number is reached, the data recorder enters the FWD mode and the tape is reproduced. When the PAUSE button is pressed during searching, the unit enters the PAUSE mode after finding top of the ID number entered.
- 2) To perform a search during reproduction by pressing the FWD button, press the F-FWD button or the REW button while in the FWD mode. The unit searches the tape for the ID number of [display value + N] and enters the FWD reproduction mode when the F-FWD button is pressed N times. The unit searches the tape for the ID number of [display value - (N - 1)] and enters the FWD reproduction mode when the REW button is pressed N times.

5-11) End Search (E SEARCH)

The E SEARCH button can be used to record data following a recorded portion on a tape.

(1) When no E mark is recorded

Pressing the button searches for the end of the recorded portion from BOT, and the tape stops running.

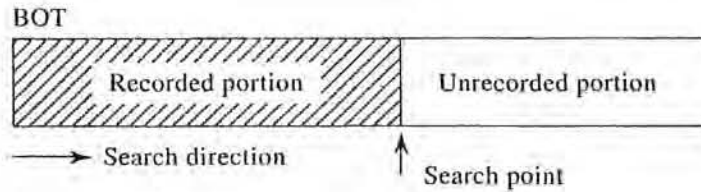

(2) When the E mark is recorded

Pressing the button searches for the E mark from BOT and the tape stops running immediately before the E mark.

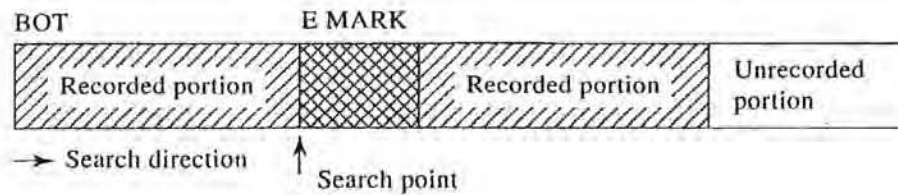

In either case shown above, when recording starts from the tape position after search operation, recording continues from BOT.

(3) Use of E marks

Use the E mark to indicate the end of new recording on a recorded tape. If more than one E mark is recorded on a tape, the tape is searched for first E mark from BOT. Record only one E mark on a tape.

5-12) Erasure

For the R-DAT cassette tape used in this unit, previous recordings are replaced by new recordings when a recording is made again on a recorded tape. Since previous recordings remain in the portions where rerecording is not made, data, memo, ID, COUNTER, and CLOCK are reproduced. When these data items interrupt data output or search operation, use the cassette tape whose entire contents are demagnetized by a bulk tape eraser. Because the R-DAT cassette tape is very difficult to erase, take enough time erasing both sides of the tape with the bulk tape eraser.

If there are portions left unerased, they may cause meaningless numbers to appear in the COUNTER, ID, and CLOCK displays and search or end search may operate abnormally.

90197561



5-13) Digital Channel Mode

The RD-145T allows selection of CH1 in normal analog input mode or digital channel mode. In the digital channel mode, digital signals in 14 bits parallel format can be recorded or reproduced through a 37P multi-connector on the rear panel, and the bit rate is equal to the sampling rate for the analog input. Various status signals, externally converted A/D data, etc. can be recorded and reproduced with analog signals in other channels.

① Setting and releasing of the digital channel mode

When STOP mode or no tape loaded, pressing either one of ◀ or ▶ of CH select buttons and the COUNTER MODE button simultaneously for 3 sec lights up the CH1/DIO LED just side of the CH1 INPUT BNC connector and the unit enters the digital channel mode. To return to the original analog mode, press either one of CH select buttons (◀, ▶) and the COUNTER MODE button simultaneously for 3 sec again and the CH1/DIO LED lights off and the unit enters the analog input mode.

When a tape recorded with the digital channel mode is reproduced in the FWD mode, the unit automatically enters the digital channel mode and the data reproduced is obtained at the 37P multiconnector.

Note: • In the digital channel mode, the CH1 bar meter does not light up. Moreover, setting of the monitor select input range is not allowed for the CH1.

• When a tape recorded with the analog input mode is reproduced in the digital channel mode, the CH1/DIO LED lights off and the CH1 reproduces the analog signals.

② I/O circuit type

• Input circuit type (DI 0 to 13)

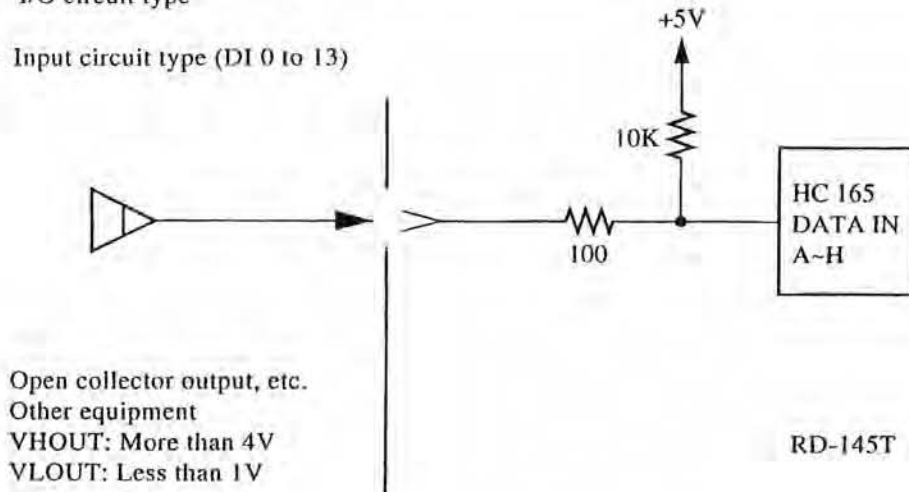

• Output circuit type (DO 0 to 13, IN STB, OUT STB)

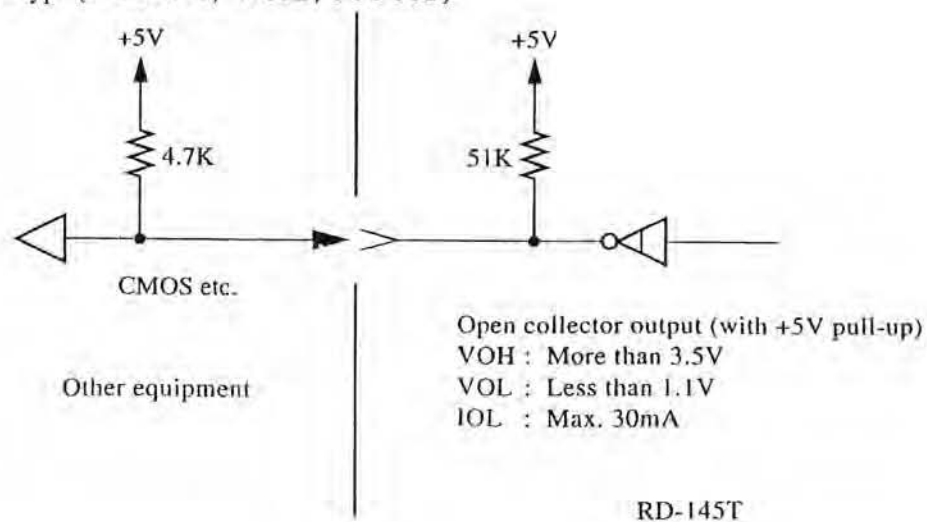

90197562



③ I/O timing specifications

• Input timing

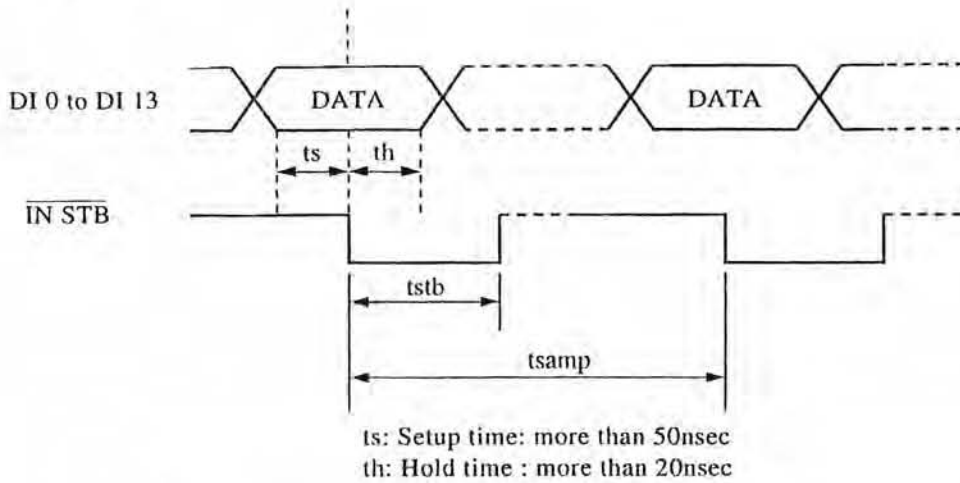

| Tape speed MPX | tsamp (μ sec) | tstb (μ sec) |
|-----------------|--------------------|-------------------|
| x2 speed CH1-4 | 20.83 | 5.2 |
| x2 speed CH1-8 | 41.67 | 5.2 |
| x2 speed CH1-16 | 83.34 | 10.4 |
| x1 speed CH1-2 | 20.83 | 10.4 |
| x1 speed CH1-4 | 41.67 | 10.4 |
| x1 speed CH1-8 | 83.33 | 10.4 |
| x1 speed CH1-16 | 166.67 | 20.8 |

• Output timing

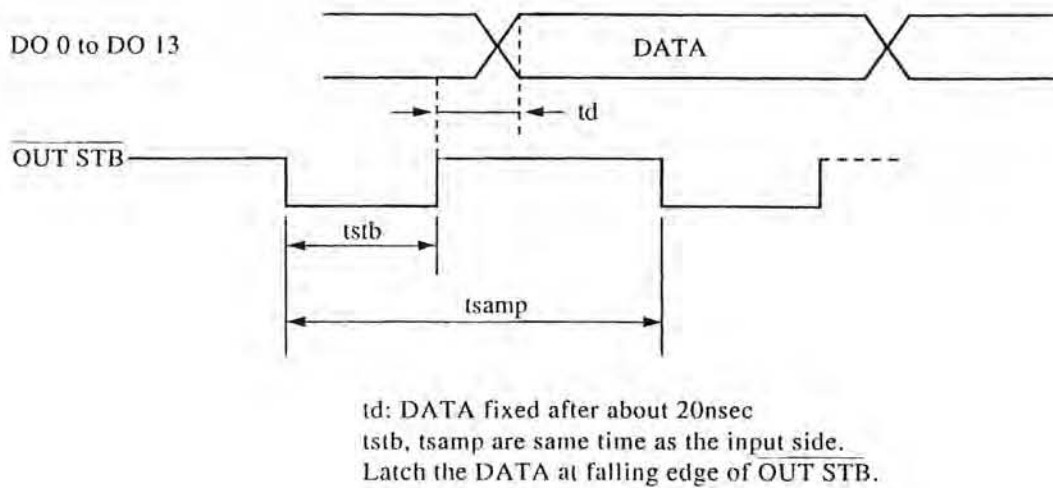

90197563

1 入 2

④ I/O connector signal table

Connector: Dsub 37 pins, socket side

| Pin No. | Signal name | Pin No. | Signal name |
|---------|----------------------------|---------|-----------------------------|
| 1 | DI 0 | 20 | DO 0 |
| 2 | DI 1 | 21 | DO 1 |
| 3 | DI 2 | 22 | DO 2 |
| 4 | DI 3 | 23 | DO 3 |
| 5 | DI 4 | 24 | DO 4 |
| 6 | DI 5 | 25 | DO 5 |
| 7 | DI 6 | 26 | DO 6 |
| 8 | DI 7 | 27 | DO 7 |
| 9 | DI 8 | 28 | DO 8 |
| 10 | DI 9 | 29 | DO 9 |
| 11 | DI 10 | 30 | DO 10 |
| 12 | DI 11 | 31 | DO 11 |
| 13 | DI 12 | 32 | DO 12 |
| 14 | DI 13 | 33 | DO 13 |
| 15 | $\overline{\text{IN STB}}$ | 34 | $\overline{\text{OUT STB}}$ |
| 16 | 0V | 35 | 0V |
| 17 | 0V | 36 | 0V |
| 18 | 0V | 37 | +5V |
| 19 | +5V | | |

Note: +5V output allows maximum load of 100mA.

⑤ Analog channel and time relation

The digital channel data, which differs from analog channel data, are recorded and reproduced without passing through analog and digital filters, so, they are output at a fast timing when compared with those in the analog channel. The time is as shown below.

- X2 speed CH1-4 approx. 1.7msec
- X2 speed CH1-8 approx. 3.4msec
- X2 speed CH1-16 approx. 6.8msec
- X1 speed CH1-2 approx. 1.7msec
- X1 speed CH1-4 approx. 3.4msec
- X1 speed CH1-8 approx. 6.8msec
- X1 speed CH1-16 approx. 13.6msec

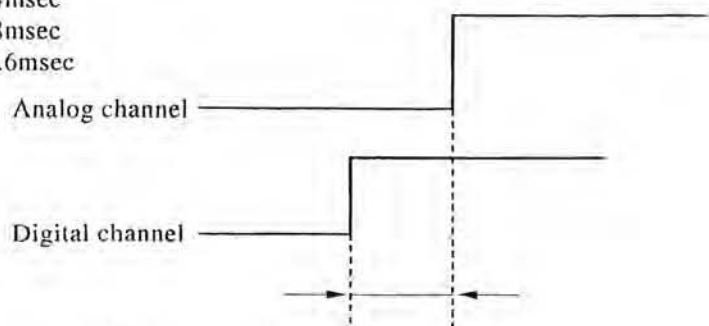

90197564



6. MAINTENANCE

As a helical scanning rotary head is used in this unit, the maintenance for this unit is a little different from that of an analog recording data recorder. Read the following explanations and follow the maintenance procedures.

6-1) Cleaning the Head before Recording

Before recording is performed (once a day) or if the MPX ERROR indicator lights despite correct operation during reproduction or if a waveform is missing, clean the rotary head by using the attached cleaning tape. As soon as loading the cleaning tape, run it for about 10 seconds with x1 tape speed by pressing the FWD button, then unload it. Do not run the cleaning tape for longer than 10 seconds; otherwise the tape will abrade the head.

The attached TZ-350H cleaner kit is used to clean the guides, pinch roller, and so on. Do not wipe the rotary head with the cleaning fluid, otherwise dirt will adhere to the head and around it, causing problems like catching of the tape. Care must be taken.

6-2) Cleaning the Running System

If the running system is very dirty when viewed from the gap in the cassette compartment, clean the running system (except for the rotary head) as shown in the following figure once every 20 to 30 hours using the attached TZ-350H cleaner kit. Remove the four screws for fixing the cover of the cassette compartment with the Phillips screwdriver and wipe with a cotton swab.

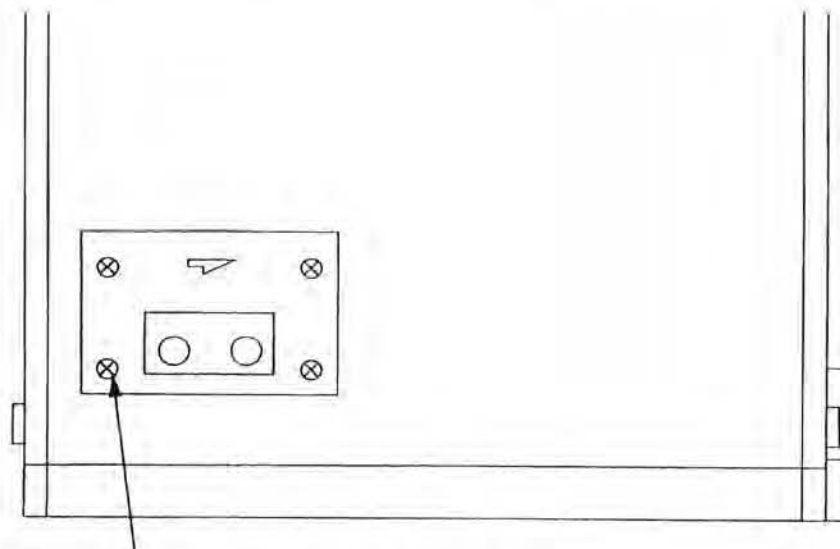

Remove four M2 plastic setscrews attaching the lid of the cassette compartment.

90207948

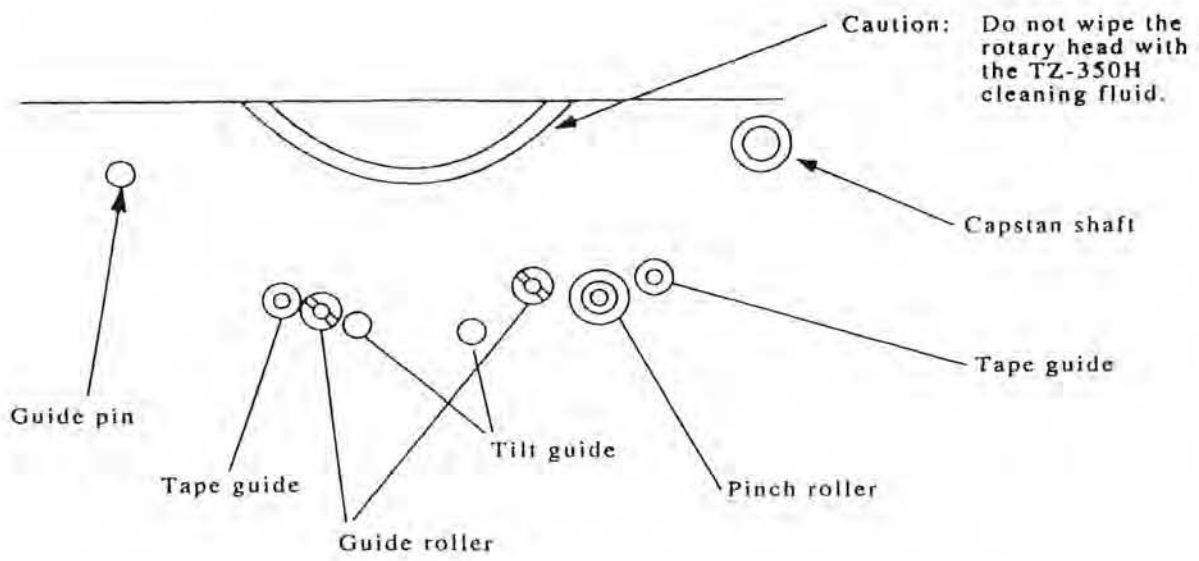

Parts to be cleaned with the TZ-350H cleaning kit
(running-system parts which are visible when the cassette compartment is removed)

6-3) Action to Be Taken When the Tape is Caught by the Rotary Head

If the tape becomes tangled around the head due to condensation, immediately turn off the power and contact your nearest TEAC distributor. In case of emergency, take the following measure and contact a TEAC service agency.

- 1) Turn off the power and disconnect the power cable.
- 2) Remove the setscrews (2 pcs. on top and 8 pcs. on the rear panel) for the cassette compartment and slide the top cover backward.

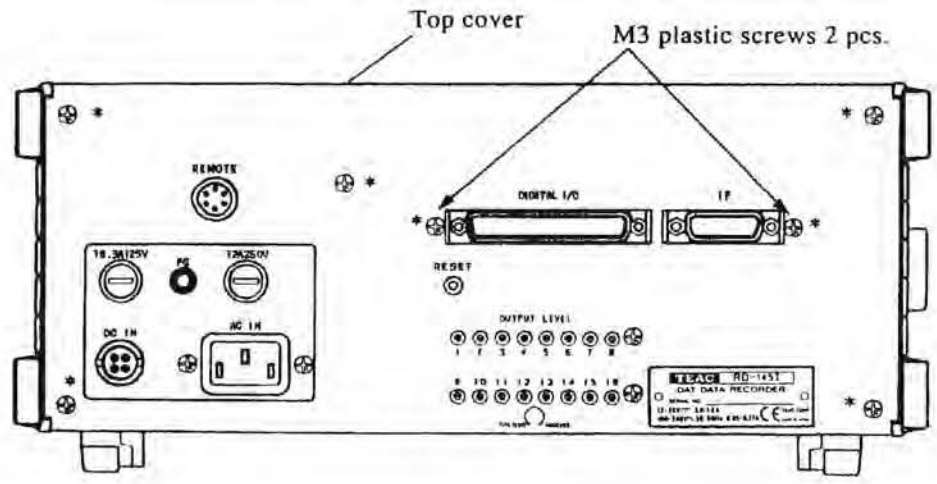

- 3) Loosen the screws on the rotary head cover and remove it.
- 4) Manually turn the rotary head catching the tape about one turn clockwise.
- 5) Lead out the slack tape with tweezers or a ball-point pen when the caught tape becomes slack. Lead out more tape, turning the rotary head clockwise to untangle the tape.

- 6) Press down the lever in front of the cassette tape to open the cassette compartment.

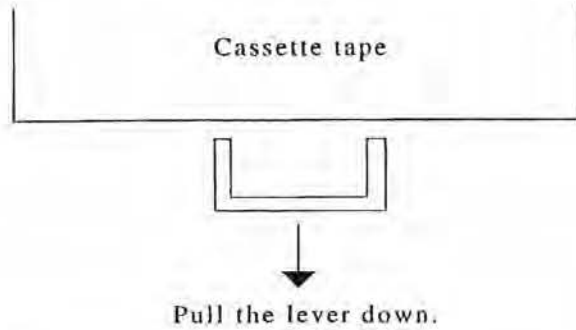

- 7) Take out the cassette tape slowly and draw the tape into the cassette.

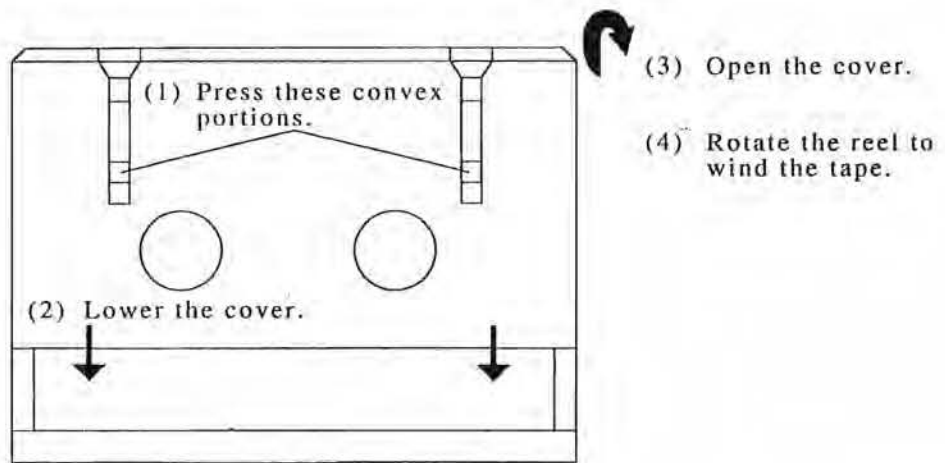

- 8) Check whether any foreign material has adhered to the drum where the tape was tangled by turning the rotary head slowly. Wipe off any foreign material with a cotton swab moistened with cleaning fluid of the TZ-350H cleaner kit. Do not wipe the rotary head, however.
- 9) After cleaning, slowly wipe the surface of the drum with a dry cotton swab. Care must be taken to prevent fragments of the cotton swab from adhering to the drum.
- 10) After the drum dries, turn on the power and allow 10 to 20 minutes for the unit to warm up.
- 11) Run the cleaning tape for about 10 seconds, then eject the cleaning tape, turn off the power, and install the top cover and the lid of the cassette compartment.
Plastic screws are used to secure a part of the top cover and the cassette compartment cover, so they will be damaged if too tightened. To prevent this tighten the screws with specified torque shown below.
- Top cover M3 plastic screws 2 pcs.800g·cm
 - Cassette compartment cover M2 plastic screws 4 pcs.350g·cm
- 12) Check that the unit is functioning properly by recording and reproducing with a new cassette tape.

Note:

- Do not re-insert the damaged tape.
The tape may cause a problem because it is nearly worn out, a flow is made on it, or dust adheres to the rotary head.
- Do not clean the head section with alcohol, cotton swab, etc.
Always use the cleaning cassette attached.



7. CONFIGURATION

| | |
|---|---|
| Tape transport: | 1 |
| HEAD AMP PCBA | |
| TTP I/F PCBA: | 1 |
| Servo, signal processing, error correction, control, etc. | |
| CONTROL (1) PCBA: | 1 |
| CONTROL (2) PCBA: | 1 |
| AD/DA PCBA: | 2 |
| Front panel assembly: | 1 |
| Power supply unit: | 1 |
| Chassis: | 1 |

8. STANDARD ACCESSORIES

| | |
|----------------------------------|------------|
| R-DAT cassette tape: | 1 |
| BNC cable: | 33 |
| Connector 37P (digital I/O) | 1 |
| Connector cover | 1 |
| Slotted screw driver | 1 |
| ac power cable: | 1 |
| dc power cable: | 1 |
| Microphone: | 1 |
| Earphone: | 1 |
| R-DAT cleaning tape: | 1 |
| Cleaner kit: | 1 |
| Fuse (2A for ac, 6.3A for dc): | 1 for each |
| Vinyl bag for accessory storage: | 1 |
| Caution label: | 1 |
| Instruction Manual: | 1 |

9. OPTIONS

9-1) Rechargeable Battery Unit BU-41

| | |
|----------------------|--|
| Battery capacity: | 12 V 6.5 Ah/20 HR |
| Recording time: | Approx. one hour continuously (when fully charged at the room temperature) |
| Charging method: | The charge function is provided for in the power supply of this unit. |
| Protect function: | Overdischarge protective function (provided for in the power supply unit) Circuit breaker for protection against overcurrent |
| Installation method: | Installed with screws at the rear of the recorder. |
| Weight: | Approx. 2.6 kg (5.7 lbs) |
| Dimensions: | Approx. 240 (W) x 109 (H) x 75 (D) mm (9 ⁷ / ₁₆ x 4 ⁵ / ₁₆ x 2 ¹⁵ / ₁₆ in.) (excluding protrusions) |

9-2) Battery Charger BU-41CH

| | |
|---------------------|--|
| Available battery: | Dedicated to the BU-41 (BU-40 is also available) |
| Charging time: | Approx. three hours (Two units can be charged in parallel.) |
| Power requirements: | 90 to 130 Vac or 180 to 264 Vac |
| Dimensions: | Approx. 190 (W) x 90 (H) x 270 (D) mm (7 ¹ / ₂ x 3 ⁹ / ₁₆ x 10 ⁵ / ₈ in.) (excluding protrusions) |

9-3) Remote Control Unit ER-40

| | |
|---------------------|--|
| Control: | REW, F-FWD, PAUSE, FWD, STOP, and REC push-button switches (Note) Tape speed switching function is not provided. |
| Microphone: | A microphone input connector and LOCK feature of the microphone press talk switch are provided. |
| ID: | The EVENT switch is provided. |
| Power supply check: | A low voltage indicator is provided for when the unit is used with dc power. |
| Cable length: | Approx. 5 m (16.4 ft) |
| Weight: | Approx. 550 g (1.21 lbs) |
| Dimensions: | Approx. 165 (W) x 55 (H) x 64 (D) mm (6 ¹ / ₂ x 2 ³ / ₁₆ x 2 ¹ / ₂ in.) (excluding protrusions) |

9-4) Fixed Handle for Vehicle TZ-701

9-5) Rack-mount Adaptor TZ-705 RME/RMJ

9-6) GPIB Interface Unit GP-302

| | |
|---------------------|---|
| Power requirements: | 90 to 250 Vac, approx. 20VA |
| Functions: | Transport control and retrieval (Note) Tape speed switching function is not provided. |
| Weight: | Approx. 3.5 kg (7.7 lbs) (including MB-300) |
| Dimensions: | Approx. 306 (W) x 48 (H) x 377 (D) mm (12 ¹ / ₁₆ x 1 ⁷ / ₈ x 14 ¹³ / ₁₆ in.) (excluding protrusions) |

9-7) Memory Board MB-300

| | |
|----------------------|---------------------|
| Installation method: | Built in the GP-302 |
| Memory capacity: | 3M bytes |

- (Note 1) Not used in reproduction mode at tape speed x2, use at tape speed x1.
(Note 2) Data transfer is impossible when used recorded tape by CH1-16 mode.



10. SPECIFICATIONS

10-1) Major Specifications

| | |
|------------------------------------|--|
| Recording and reproduction method: | Analog input and output system by multiplexing PCM recording and reproduction |
| Tape used: | DAT standard tape Hitachi Maxell tapes are designated. DM120 tape length: 60 m tape width: 3.81 mm DM60 tape length: 30 m tape width: 3.81 mm |
| Recording format: | Note: Refer to 3-5) "Cassette Tape" on page 5. Conforms to the helical scanning R-DAT format. |
| Number of quantization bits: | 16 |
| Recording data length: | High-order 14 bits of quantization bits |
| Head | |
| Recording and reproduction: | 4 heads: 2-head azimuth system (for recording) 2-head azimuth system (for reproduction) |
| (Erasure): | (Erasure method by overwriting) |
| Error correction method: | Double-encoded Reed-Solomon Code System |
| Tape speed: | x1: 8.15 mm/s, x2: 16.3 mm/s (during recording or reproduction) |
| Head rotational speed: | x1: 2000 rpm, x2: 4000 rpm (during recording and reproduction) |
| Recording time: | x1: 2 hours, x2: 1 hour (during continuous recording with a 60-m tape (DM-120)) x1: 1 hour, x2: 30 minutes (during continuous recording with a 30-m tape (DM-60)) |
| Start or stop time: | Approx. 2 seconds |
| Fast-forward or rewind time: | Approx. 60 seconds (for a 60-m tape (DM-120)) |

10-2) I/O Specifications (Analog Channel)

| | |
|-------------------|--|
| Input voltage: | ± 0.5 Vp, ± 2 Vp, ± 5 Vp, ± 20 Vp max. |
| Input impedance: | 100 k Ω unbalanced (nominal) |
| Input filters: | Both an analog filter and a 64-fold over-sampling digital filter are used. |
| Output voltage: | ± 2 Vp to ± 5 Vp (load resistance 100 k Ω or more) |
| Output impedance: | 75 Ω (nominal) |

Number of data channels and recording and reproduction frequency:

| Tape Speed | x1 (8.15 mm/s) | x2 (16.3 mm/s) |
|--------------------------------------|---|---|
| Number of data channels | 2, 4, 8 or 16 (changeover) | 4, 8 or 16 (changeover) |
| Sampling rate | 48 kHz/24 kHz/12 kHz/6 kHz | 48 kHz/24 kHz/12 kHz |
| Recording and reproduction frequency | dc to 20 kHz/dc to 10 kHz/ dc to 5 kHz/dc to 2.5 kHz | dc to 20 kHz/dc to 10 kHz/ dc to 5 kHz |

Note: Speed conversion will be made in the record and reproduce mode. However, tape recorded in the data 2 channel mode at speed of 8.15 mm/sec can not be reproduced at x2 (16.3 mm/sec) speed.

10-6) Others

Power system: Switching regulator system
Supply voltage (for ac/dc): Usable voltage and frequency (The values in parenthesis are rated values.)
90 to 264 (100 to 240) Vac
48 to 440 (50 to 60) Hz
11 to 30 (12 to 28) Vdc
Automatic ac/dc changeover (ac precedes dc, however)
The LOW BATT alarm function operates at approx. 11 Vdc or less.
Output is cut off at approx. 10.2 Vdc or less. (Overdischarge protection function)
Current consumption: Approx. 0.85 A with 100 Vac
Approx. 3.6 A with 12 Vdc
Dimensions (W x H x D): Approx. 306 x 128 x 280 mm (12¹/₁₆ x 5¹/₁₆ x 11 in.)
(excluding protrusions)
Weight: Approx. 7.5 kg (16.5 lbs)

90207949

12

10-7) External View

Dimensions

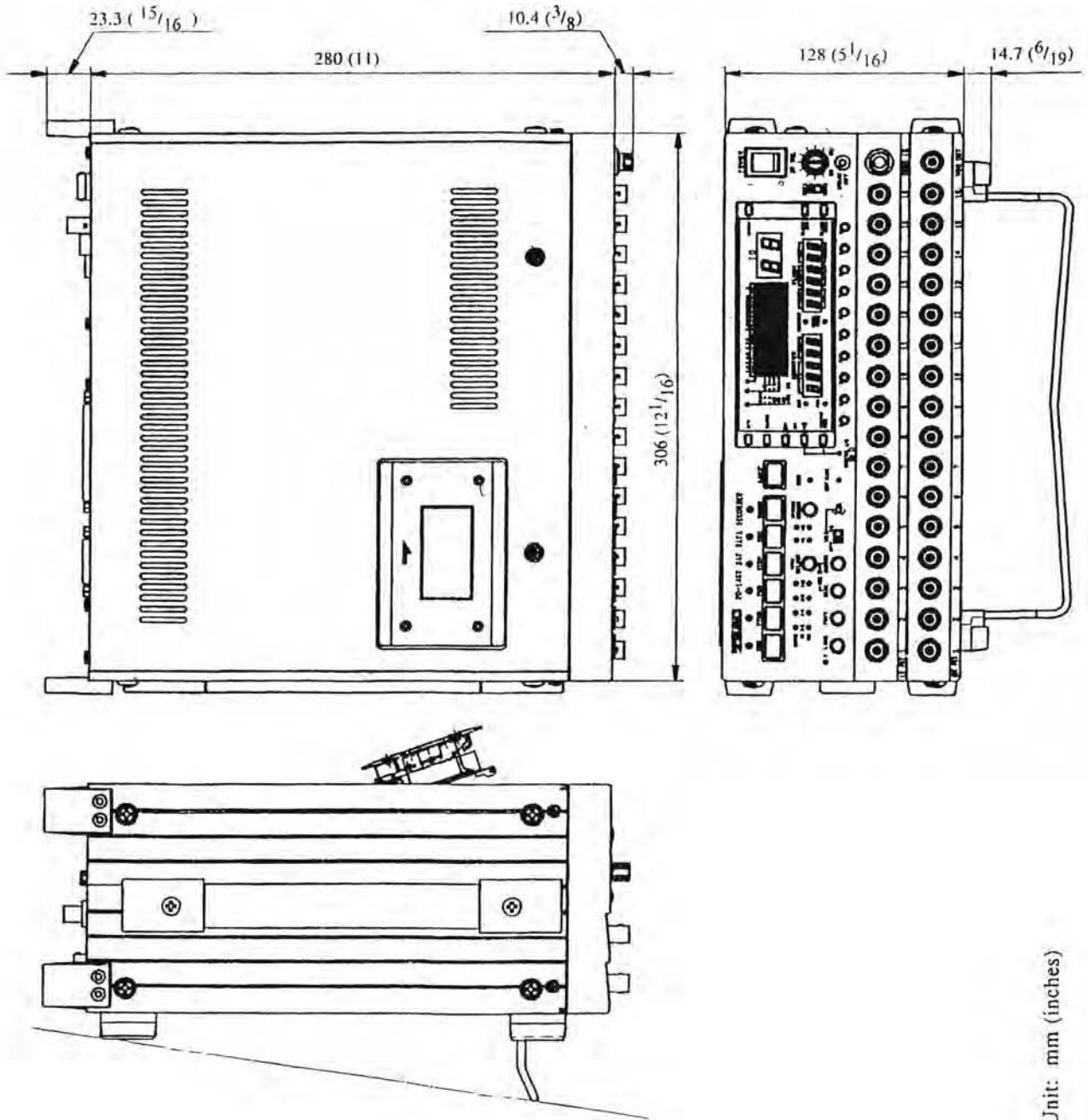

Unit: mm (inches)

90197573

3A3903

1/2

情報機器営業品目(Information Products)

- 計測用データレコーダ(Data Recorders)
- 計測用各種センサおよび直流増幅器
(Sensors&Amplifiers)
- コミュニケーションレコーダ
(Communications Recorders)
- 大容量デジタル磁気テープ記憶装置
(Mass Storage Products)
- ビデオテープレコーダ(Video Tape Recorders)
- ビデオディスクレコーダ(Video Disk Recorders)
- FA機器

周辺機器営業品目(Computer Peripheral Products)

- フロッピーディスクドライブ(Floppy Disk Drives)
- CD-ROMドライブ(CD-ROM Drives)
- デジタル磁気テープ記憶装置(Tape Streamers)

その他のティアック製品(Other Products)

- パーソナルコンピュータ関連機器
- オーディオ&ビジュアル機器(Audio&Visual Products)
- 環境機器

ティアック株式会社

〒180 東京都武蔵野市中町3-7-3

製品に関するお問い合わせは…

- | | | |
|----------|-------|--------------------|
| 電子機器事業部 | 電 話 | (0422)52-5010、5012 |
| 情報機器 DIV | F A X | (0422)52-1390 |
| 周辺機器事業部 | 電 話 | (0422)52-5046、5047 |
| 国内営業部 | F A X | (0422)55-2582 |
| 茨城出張所 | 〒300 | 土浦市東崎町11-5山本ビル |
| | 電 話 | (0298)24-2865(代) |
| | F A X | (0298)24-2866 |
| 名古屋営業所 | 〒465 | 名古屋市名東区上社5-406 |
| | 電 話 | (052)702-2351(代) |
| | F A X | (052)702-3107 |
| 大阪営業所 | 〒564 | 吹田市垂水町3-34-10 |
| | 電 話 | (06)384-6041(代) |
| | F A X | (06)385-8849 |
| 広島営業所 | 〒730 | 広島市中区西川口町13-19 |
| | 電 話 | (082)294-4751(代) |
| | F A X | (082)294-4669 |
| 福岡営業所 | 〒812 | 福岡市博多区東光2-2-24 |
| | 電 話 | (092)441-3600(代) |
| | F A X | (092)472-7602 |

修理に関するお問い合わせは…

- | | | |
|---------|-------|-------------------|
| 電子機器事業部 | サービス部 | サービス2課 |
| | 電 話 | (0422)52-5068 |
| 周辺機器事業部 | 業務部 | フィールドエンジニアリンググループ |
| | 電 話 | (0422)52-5069 |
- および上記営業所、出張所

Head Office:

TEAC CORPORATION

3-7-3 Naka-cho, Musashino, Tokyo, 180, Japan
ELECTRONICS AND INFORMATION PRODUCTS DIVISION
Tel:(0422)52-5016, 5014 Fax:(0422)52-1990

U.S.A.:

TEAC AMERICA, INC.

7733, Telegraph Road, Montebello, California
90640, U.S.A.
Tel:(213)726-0303 Fax:(213)727-7621

CANADA:

TEAC CANADA LTD.

340 Brunel Road, Mississauga Ontario L4Z 2C2
Tel:(416)890-8008 Fax:(416)890-9888

Germany:

TEAC DEUTSCHLAND GmbH.

Bahnstrasse 12, D65205 Wiesbaden-Erbenheim, Germany
Tel:0611-71580 Fax:0611-715811

RD-145T DAT DATA RECORDER
ACCESSORIES AND SPARES

| | | |
|---------------------------|-------------|--------|
| R-DAT Cassette Tape DM120 | 14800108 | 1 |
| R-DAT Cleaning Tape | 14800128 | 1 |
| Cleaner Kit TZ-350H | 17930220-02 | 1 |
| Input/Output Cable | 15922849-00 | 33 |
| Microphone | 15990460-00 | 1 |
| Earphone | 15990330 | 1 |
| Vinyl Case | 10990910-00 | 1 |
| Vinyl Cover | 10992242-00 | 1 |
| Power Cable (AC) | 15922282 | 1 |
| Power Cable (DC) CL-63 | 15922836-00 | 1 |
| Fuse DC (6.3A) | E0036730 | 1 |
| Fuse AC (2A) | 13297185 | 1 |
| Caution Label | 10023175-00 | 1 |
| Connector 37P | 13124825 | 1 |
| Cover Connector 37P | 16362968 | 1 |
| Driver | 16910032 | 1 |
| | | |
| Instruction Manual | 10111431-10 | 1 copy |