

FEATURES

- Four high resolution delay channels
 - 1 ps resolution
 - < 25 ps rms jitter
 - > 20 second delay range
- Option: Four auxiliary delay channels
- Compact packaging
- All parameters may be controlled via front panel, Ethernet or Internet

APPLICATIONS

- Components test
- ATE
- Laser timing
- Precision pulse
- Instrument triggering



DESCRIPTION

The Model 745T generator provides four independent delay channels (A to D) to the front panel. The delay resolution is 1 ps, and external trigger-to-channel jitter is less than 25 ps. BNC outputs deliver 5 V, 2 ns rise time, at 50 Ω impedance. Amplitude and width are adjustable on each output pulse.

One input trigger (TRIG IN), or two internal timers, or software command is used to trigger all output channels.

A T0 output pulse is the time reference of the delay and generates at each selected trigger event.

The Model 745T also provides (optionally) four auxiliary delays channels (E to H) to the front panel. The delay resolution is 1.25 ns and trigger-to-channel jitter is less than 50 ps.

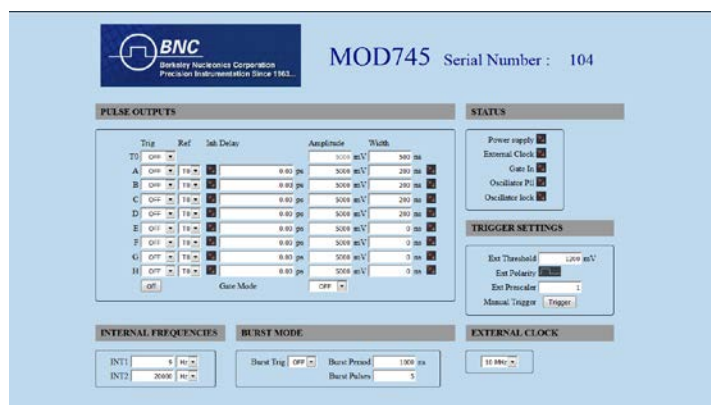

Example of Model 745T control panel

Control panel Web page:

This web page, from an embedded Web server, provides a simple method to configure settings for each channel (delay, output amplitude, output width), trigger source, trigger mode, and to control operation and status of the instrument.

The configuration information of the instrument is stored and saved in the Model 745T.

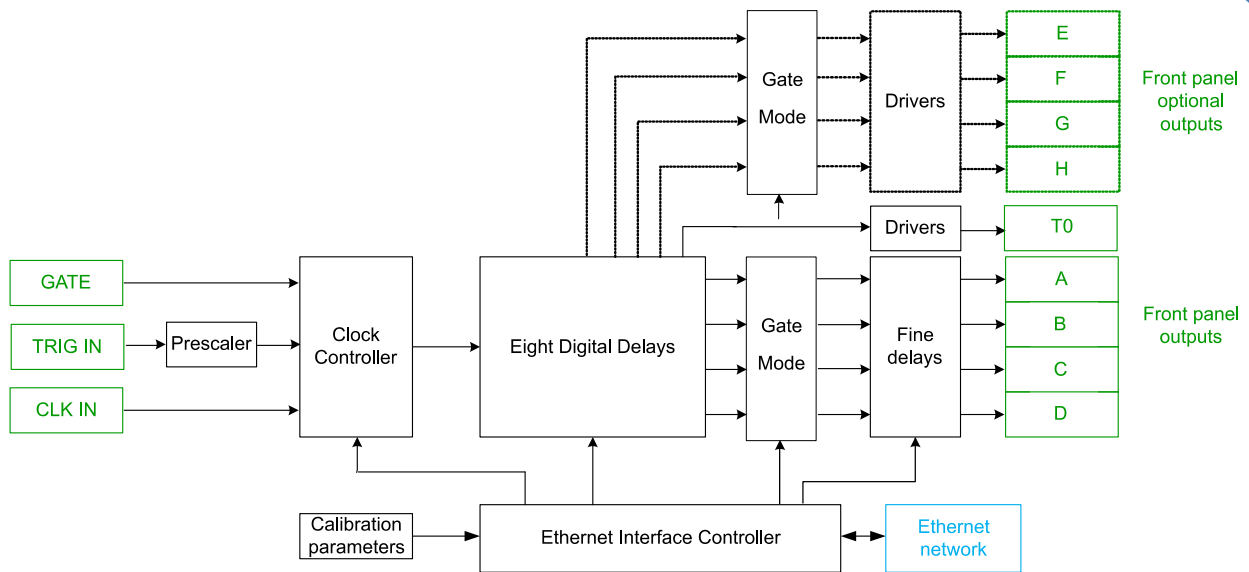

Block diagram

SPECIFICATIONS

Delays A to D

Channels	4 independent delay outputs
Range	0 to > 20 seconds
Resolution	1 ps
RMS Jitter	25 ps + delay x 10 ⁻⁸ (external trigger to any output)
Accuracy	< 250 ps + delay x 10 ⁻⁸
Time base	50 ppb stability

Output A to D

Amplitude	2 to 5 V, step < 0.1 V / 50 Ω
Width	100 ns to 10 μs, 5 ns resolution
Rise / Fall time	< 2 ns / < 5 ns
Connector	BNC on front panel

Trigger source

Command	Front panel / Ethernet / USB
Internal	Two Timers, F = 0.25 Hz to 1 MHz
External	Repetition rate < 1MHz Trigger Prescaler : 1 to 2 ¹⁶ -1 Trigger level, from 0.1 to 5V / 50Ω Positive or negative slope Minimum trigger delay < 65 ns

Trigger mode Single, repetitive or burst

Burst Mode

Pulse Number	1 to 2 ¹⁶ -1
<i>Period between pulses</i>	
Range	1 μs to 1 s
Resolution	5 ns

Output T0 5 V / 50 Ω, 200ns
BNC on rear panel

Gate input

Threshold	1.5 V
Polarity	Active high
Function	Pulse inhibit
Channel behavior global or individual channel enables	

Clock IN/OUT

CLK in	10 or 80MHz, 50% duty cycle. Ask factory for custom clock frequency
CLK out	10 or 80MHz (directly related to the input clock)

User memory

Up to 4 sets of Model 745T parameters can be stored/recalled via Front Panel, Ethernet or USB

General specifications

Size	215 x 245 x 135 mm
Power	50 W – 110 to 240 V

Interface control

Front panel,
Web page from embedded web server. Compatible with IE, Firefox, Chrome
USB (serial communication) and Ethernet link

Options

Option 1: 4 auxiliary delay channels E to H

Delay

Channels: 4 independent delay output,
Range: 0 to > 20 seconds,
Resolution: 1.25 ns
Jitter < 50 ps rms + delay x 10⁻⁸ (external trigger to any output)
Accuracy: 1 ns + delay x 10⁻⁷

Output

Amplitude: 5V / 50 Ω,
Width: 100 ns to 10ms, 5ns resolution
Rise, Fall time < 5 ns
Connector: BNC on front panel